

STANDARD BIDDING DOCUMENT

Procurement of Small Works

ཕྱི་ལོ་ལྷན་ཁག་བཅའ་ཁྲིམས་ལྟར་ རྒྱུ་ལེན་གྱི་ཐོག་ལྟོས་



**Name of work: CONSTRUCTION OF 4 UNIT TOILET AT
TSIRINGTOED CENTRAL SCHOOL UNDER
TSIRINGTOED GEOG**

Tender Sale: From 18/02/2019 To 27/02/2019

	Date & Time	Place
Bid Submission	27/02/2019, Before 10.00 AM	DZONGKHAG PROCUREMENT OFFICE.
Bid Opening	27/02/2019, at 10.30 AM	DZONGKHAG CONFERENCE HALL.



ཇོང་ཁག་བདག་སྐྱོང་ཚེ་རང་།
DZONGKHAG ADMINISTRATION
TSIRANG
"Towards Quality Infrastructure"



DAT/DES-10/2018-2019/ 260

Date: 15th February 2019

Invitation for Bids

The Dzongkhag Administration, Tsirang invites sealed Bids from eligible and qualified Bidders for the execution of following work;

S.no	Name of Work	Estimate Amount(Mn)	Contract Duration	EMD (Nu)	Category	Sale Dates
1	Minor maintenance and conversion of Administrative block to Traditional Medicine Unit	Nu.0.497	3 Months	9,900	W3/S	18-27/2/2019
2	Construction of Water Reservoir tank at Shemjong BHU	Nu. 1.32	3 Months	26,500	W1/S	18-27/2/2019
3	Construction of 2 unit toilet and Renovation of old MPH at Shemjong Pry School	Nu. 4.378	9 months	88,000	W3/M	18-27/2/2019
4	Remodeling of cottage (Stone & Mud wall) & Conversion of old Generation House into Staff quater at Damphu Center School	Nu. 2.91	8 months	58,200	W3 /S	18-27/2/2019
5	Maintenance works at Dratsang	Nu.0.852	1.5 months	17,100	W4/S	18-27/2/2019
6	Construction of 4 Unit toilet at Tsiringtoed Central School.	Nu.1.086	3 Months	22,000	W3 /S	18-27/2/2019
7	Construction of 4units PF Toilet at Mendrelgang CS (Boys)	Nu.0.480	2 months	9,600	W3/S	18-27/2/2019
8	Development of playground and construction of approach road to sergithang PS under Sergithang Gewog	Nu 2.201	3 months	44,000	W1/S	18-27/2/2019
9	Maintenance of RNR staff Quarter drainage system at Sergithang under Sergithang Gewog	Nu.0.349	3 months	7,000	W3/S	18-27/2/2019
10	Site development work at patsaling BHU	Nu. 0.371	2 months	7,400	W1/S	18-27/2/2019
11	Installation of Compound light at DVH	Nu .0.633	1.5 months	13,000	W4/S	18-27/2/2019
12	Electrification & Maintenance of Dzong bacho	Nu.0.455	1.5 months	9,100	W4/S	18-27/2/2019
13	Development of playground at Tsholingkhar PS	Nu 2.68	3 months	54,000	W1/S	18-27/2/2019
14	Construction of 6 Unit Classroom at DCS	Nu 12.311	12 months	246,500	W3/M	18/2-19/3/2019
15	Electrification & Landscaping of Dzong area	Nu. 1.743	3 months	35,000	W4/S	18-27/2/2019
16	Re-electrification and maintenance of Mendralgang BHU and Staff Quarter	Nu.0.758	3 months	15,200	W3/S	18-27/2/2019
17	Construction of 4units PF Toilet at Mendrelgang CS (Girls)	Nu.0.669	2 months	13,300	W3/S	18-27/2/2019

1. Bidding will be conducted through the limited Competitive Bidding procedures specified in the RGoB Procurement Manual, and are open to all Bidders from Countries as defined in Section III of the Bidding Documents.
2. A complete set of Bidding Documents can be downloaded by interested bidders from the Dzongkhag website www.tsirang.gov.bt and www.cdb.gov.bt w.e.f 18th February 2019.



ཇོང་ཁག་བདག་སྐྱོང་ཅེ་རང་།
DZONGKHAG ADMINISTRATION
TSIRANG



"Towards Quality Infrastructure"

3. Bids must be delivered to the *Procurement section, Dzongkhag Administration, Tsirang* on or before **10.00 AM on 27/02/2019**. Electronic bidding *"shall not"* be permitted. Late bids will be rejected. Bids will be opened physically in the presence of the bidders' representatives who choose to attend in person at **Dzongkhag Conference hall on 27/02/2019 at 10.30 AM**
4. All Bids shall be accompanied by a Bid Security of **as mentioned above** drawn in favors of **Dasho Dzongda, Administration, Tsirang** and will have to be in any one of the forms as specified in the bidding document and should be valid for 30 days beyond bid validity.

(Pema)
DZONGDA

Copy to:

1. CDEO, Dzongkhag Adm. Tsirang for information
2. Planning Officer, Dzongkhag Adm. Tsirang for information
3. FO, Dzongkhag Adm. Tsirang for information
4. DE, Dzongkhag Adm. Tsirang for information.
5. DHO, Dzongkhag Adm. Tsirang for information.
6. DCO, Dzongkhag Adm. Tsirang for information.
7. ICTO, Dzongkhag Adm. Tsirang, for uploading the bidding documents in dzongkhag website
8. Procurement Officer, Dzongkhag Adm, Tsirang for Advertisement in kuensel
9. Office Copy

Contents

INVITATIONS FOR BIDS (IFB)	Error! Bookmark not defined.
Section 1: Instructions to Bidder (ITB)	7
A. General	7
1. Scope of Tender	7
2. Corrupt Fraudulent Collusive or Coercive Practices	7
3. Eligible Bidders	8
4. Site Visit.....	8
B. Content of Bidding Document	8
5. Contents of Bidding Documents.....	8
6. Clarification of Bidding Documents.....	8
7. Amendment of Bidding Documents	9
C. Preparation of Bids	9
8. One Bid per Bidder	9
9. Bid Preparation Costs	9
10. Language of Bid	9
11. Documents comprising the Bid	9
13. Alternative Bid	9
14. Bid Price and Discount.....	9
15. Currencies of Bid and Payment	10
16. Documents comprising the Technical Proposal.....	10
17. Documents establishing the Qualification of the Bidder	10
18. Bid Validity	10
20. Format and Signing of Bid	10
D. Submission and Opening of Bids	11
21. Sealing and Marking of Bids.....	11
22. Bid Submission Deadline	11
23. Late Bids	11
24. Modification, Substitution or Withdrawal of Bids	11
25. Bid Opening	12
E. Tender Opening and Evaluation	12
26. Confidentiality	12
27. Clarification	12
28. Bidder: Contacting the Employer	12
29. Determination of Responsiveness	12
30. Non Conformities, Errors and Omissions.....	13
31. Evaluation and Comparison of Tenders	13
32. Employer's Right to Accept or Reject any or all	13
F. Contract Award	13
33. Award Criteria	13
34. Letter of Intent to Award the Contract/ Notification of Award	14
35. Complaints	14
Section 2 - Bidding Data Sheet	15
A. General	15
B. Bidding Documents	15
C. Preparation of Bids	15
D. Submission and Opening of Bids	16
F. Award of Contract	16
Section 3 – Evaluation and Qualification Criteria	17

Section 4: Forms of Bid & Qualification Information	17
Standard Form: Form of bid.....	18
Standard Form: Qualification Information	19
Standard Form: Letter of Intent.....	20
Standard Form: Letter of Acceptance.....	21
Bank Guarantee for Bid Security.....	22
Section 5. General Conditions of Contract.....	23
1. Definitions.....	23
2. Interpretation & Documents forming the Contract	23
3. Corrupt, Fraudulent, Collusive or Coercive Practices	24
4. Governing Language and Law	25
5. Engineer’s Decision	25
6. Delegation	25
7. Communications and Notices.....	25
8. Sub- Contracting.....	25
9. Contractor’s Personnel	25
10. Welfare of Labourers & Child Labour	25
11. Safety, Security and Protection of the Environment	25
12. Access to the Site	25
13. Documents, Information.....	26
14. Property.....	26
15. Insurance	26
16. Possession of the Site	26
17. Commencement of Works	26
18. Completion of Works	26
19. Programme of Works	26
20. Early Warning	26
21. Compensation Events.....	26
22. Non-Scheduled Items of Works	27
23. Schedule of Works	27
24. Payment Certificates.....	27
25. Payments and Currency	27
26. Retention.....	27
27. Liquidated Damages.....	28
28. Performance Security	28
29. Price Adjustment	28
30. Completion	28
31. Correction of Defects.....	28
32. Taking Over	28
33. Final Account.....	28
34. Termination	28
35. Payment upon Termination	29
36. Release from Performance.....	29
37. Force Majeure	30
38. Settlement of Disputes	30
Section 6. Special Conditions of Contract	31
Section 7 – Contract Forms.....	33
Form-1.....	34
Form-2.....	35

Contract Agreement	35
Form-3.....	36
Bank Guarantee for Performance Security	36
Bank Guarantee for mobilisation advance	37

Section 1: Instructions to Bidder (ITB)

A. General

1. Scope of Tender
 - 1.1 The Employer, as **indicated in the BDS** issues this Bidding Document for the procurement of Works as specified in Section 6 (Employer's requirement): The name, identification and identification of this bidding are **provided in the BDS**.
 - 1.2 The successful Bidder will be required to complete the Works within the Time for Completion stated in the Special Conditions of Contract (SCC).
 - 1.3 Throughout this Bidding Documents;
 - (a) The term "in writing means communicated in written form with proof of receipt;
 - (b) If the context so requires, singular means plural and vice versa; and
 - (c) "day" means calendar day.
2. Corrupt Fraudulent Collusive or Coercive Practices
 - 2.1 The Royal Government of Bhutan requires that Employers and the Bidders shall observe the highest standard of ethics during the implementation of procurement proceedings and the execution of Contracts under public funds.
 - 2.2 In pursuance of this requirement, the Employer shall
 - (a) exclude the bidder from participation in the procurement proceeding concerned or reject a proposal for award; and
 - (b) declare a bidder ineligible, either indefinitely or for a stated period of time, from participation in procurement proceedings under public funds;
 - 2.3 If it, at any time, determines that the bidder has engaged in corrupt, fraudulent, collusive or coercive practices in competing for, or in executing, a Contract under the public funds.
 - 2.4 The Government defines, for the purposes of this provision, the terms set forth below as follows :
 - a) "**corrupt practice**"¹ is the offering, giving, receiving or soliciting, directly or indirectly, of anything of value to influence improperly the actions of another party;
 - b) "**fraudulent practice**"² is any intentional act or omission including misrepresentation, that knowingly or recklessly misleads, or attempts to mislead, a party to obtain a financial or other benefits or to avoid an obligation;
 - c) "**collusive practice**"³ is an arrangement between two or more parties designed to achieve an improper purpose, including to

influence improperly the actions of another party;

d) **“coercive practice”** is impairing or harming or threatening to impair or harm, directly or indirectly, any party or the property of the party to influence improperly the actions of a party.

2.5 The bidder shall be aware of the provisions on fraud and corruption stated in GCC Clause 3 and GCC Sub-Clause 34.2(d).

2.6 The RGoB requires that the Employer’s personnel have an equal obligation not to solicit, ask for and/or use coercive methods to obtain personal benefits in connection with the said proceedings.

3. Eligible Bidders 3.1 Bidders of the categories **specified in the BDS** are eligible to participate in this bidding process.

3.2 The Employer shall invite Bids using the Open Tendering Method (National Competitive Bidding) or limited tender as applicable.

3.3 The bidder shall meet the qualification requirement stated in the BDS

4. Site Visit 4.1 The Bidders, at their own responsibility and risk, is encouraged to visit and examine the Site and obtain all information that may be necessary for preparing the bid and entering into a Contract for performance of the Works. The costs of visiting the Site shall be at the bidder’s own expense.

B. Content of Bidding Document

5. Contents of Bidding Documents 5.1 The sections comprising the Bidding Document are listed below and should be read in conjunction with any Amendment issued in accordance with ITB Clause 7:

PART 1 Bidding Procedures

- Section 1: Instructions to Bidders (ITB)
- Section 2: Bidding Data Sheet (BDS)
- Section 3: Evaluation and Qualification Criteria
- Section 4: Bidding forms
- Section 5: General Conditions of Contract (GCC)
- Section 6: Special Conditions of Contract (SCC)
- Section 7: Contract Forms
- Section 8: Bill of Quantities & Specifications
- Section 9: Drawings

5.2 The Employer is not responsible for the completeness of the Bidding Document and their Addenda, if they were not obtained directly from the source stated by the Employer in the Invitation for Bids.

5.3 The Bidder is expected to examine all instructions, forms terms, and specifications in the Bidding Documents. Failure to furnish all information or documentation required by the Bidding Documents may result in the rejection of the bid.

6. Clarification of Bidding Documents 6.1 A prospective Bidder requiring any clarification of the Bidding Document shall contact the Employer in writing at the Employer’s address **indicated in the BDS**.

7. Amendment of Bidding Documents 7.1 At any time prior to the deadline for submission of Bid, the Employer may amend the Bidding Document by issuing addenda and extend the deadline for the submission of bids at its discretion. Any amendment issued shall become an integral part of the Bidding Document and shall be communicated in writing to all those who have purchased the Bidding Document.

C. Preparation of Bids

8. One Bid per Bidder 8.1 A Bidder shall submit only one (1) Bid. A Bidder who submits or participates in more than one (1) Bid shall cause all the proposals with the Bidder's participation to be disqualified.
9. Bid Preparation Costs 9.1 The Bidder shall bear all costs associated with the preparation and submission of its Bids, and the Employer shall in no case be responsible or liable for those costs, regardless of the conduct or outcome of the Bidding process.
10. Language of Bid 10.1 All documents relating to the Bid shall be in the language specified in the BDS.
11. Documents comprising the Bid 11.1 The original and copy(ies) of Bid submitted by the Bidder shall comprise the following:
- (a) The Bid form (in the format indicated in Section IV – Forms of Bid, Qualification Information, Letter of Acceptance, and Contract);
 - (b) License and certificate
 - (c) Bid Security in accordance with Clause 19;
 - (d) Priced Bill of Quantities;
 - (e) and any other materials required to be completed and submitted by Bidders, as specified in the BDS.
- 11.2 The Instruction to Bidders, Bidding Data Sheet, General Conditions of Contract, Special Conditions of Contract, Specifications and drawings are for the information of the bidders and is not required to be submitted by the bidder,
- 12 Letter of Bid and Schedule 12.1 The letter of Bid, Schedules, and all documents listed under Clause 11, shall be prepared using the relevant forms in Section 4 (Bidding Forms), if so provided in BDS. The forms must be completed without any alterations to the text, and no substitutes shall be accepted. All blank spaces shall be filled in with the information requested.
13. Alternative Bid 13.1 Alternative Bid shall not be considered in small works.
14. Bid Price and Discount 14.1 The prices and discounts quoted by the Bidder in the Letter of Bid and in the Schedules shall confirm to the requirements specified below;
- 14.2 The bidder shall submit a bid for the whole of the works described in ITB 1.1 by filling in prices for all items of the Works, as identified in Section 4, Bidding Forms. In case of admeasurements contracts, the Bidder shall fill in rates and prices for all items of the Works described

in the Bill of Quantities. Items against which no rate or price is entered by the Bidder will not be paid for by the Employer when executed and shall be deemed covered by the rates for other items and prices in the Bill of Quantities.

- 14.3 The Bid price shall take into account the cost of materials, transportation, labour, taxes, levies, overheads and profit and any other cost. The Bid price shall be fixed for the duration of performance of the Contract and shall not be subject to any adjustment on any account. The Bid price shall be applicable for the whole works described in the Drawings, Specifications and Schedule of Works.
- 15 Currencies of Bid and Payment 15.1 All prices shall be quoted in Bhutanese Ngultrum (BTN) and shall be paid in BTN.
- 16 Documents comprising the Technical Proposal 16.1 The bidder shall furnish a work plan in simple bar chart and other information if provided in BDS, to demonstrate the adequacy of the Bidders' proposal to meet the work requirements and the completion time.
- 17 Documents establishing the Qualification of the Bidder 17.1 To establish its qualification to perform the Contract in accordance with Section 3 (Evaluation and Qualification Criteria) the Bidder shall provide the information requested in the corresponding information sheets included in Section 4 (Bidding Forms)
- 18 Bid Validity 18.1 Bids shall remain valid for the period **specified in the BDS**. Any Bids which does not meet the validity requirement as per the BDS shall be rejected by the Employer as non-responsive.
- 19 Bid Security 19.1 The Bidder shall at their option furnish, as part of the Bid, a Bid Security as **specified in the BDS** issued by any reputed Financial Institutions in Bhutan and shall be valid thirty (30) days beyond the Bid validity period.
- a) Unconditional Bank Guarantee;
 - b) A demand Draft; or
 - c) Cash Warrant
- 19.2 In exceptional circumstances, prior to the expiration of the Bid validity period, the Employer may solicit the Bidder's consent to an extension of the Bid validity period. The request and responses shall be made in writing. The validity of Bid Security shall be suitably extended promptly.
- 19.3 The Bid Security may be forfeited:
- (a) if the Bidder withdraws the Bid after Bid opening during the period of Bid validity. Further the bidder may be excluded from future participation for a period of two years.
 - (b) if the Bidder does not accept the correction of the Bid price, pursuant to clause 31; or
 - (c) in the case of a successful Bidder, if the Bidder fails within the specified time limit to sign the Agreement; or furnish the required Performance Security.
- 20 Format and 20.1 The Bidder shall prepare one (1) original of the documents comprising

- Signing of Bid the Bid as described in ITB Clause 11 and clearly mark it “ORIGINAL.” In addition, the Bidder shall prepare the number of copies of the Bid, as specified in the BDS and clearly mark each of them “COPY.” In the event of any discrepancy between the original and the copies, the original shall prevail.
- 20.2 The original and each copy of the Bid shall be typed or written in indelible ink and shall be signed by the person duly authorized to sign on behalf of the Bidder.
- 20.3 Any interlineations, erasures, or overwriting shall be valid only if they are signed or initialled by the person(s) signing the Bid.

D. Submission and Opening of Bids

- 21 Sealing and Marking of Bids
- 21.1 The Bidder shall enclose the original in one (1) envelope and all the copies of the bid in another envelope, duly marking the envelopes as “ORIGINAL” and “COPY.” These two (2) envelopes shall then be enclosed in one (1) single outer envelope.
- 21.2 The inner envelopes shall:
- (a) Be signed across the seals by the person authorised to sign the Bid on behalf of the Bidder;
 - (b) Be marked “ORIGINAL” and “ COPY” and
 - (c) Bear the name and address of the Bidder.
- 21.3 The outer envelope shall;
- (a) Be sealed with adhesive or other sealant to prevent reopening;
- 21.4 be addressed to the Employer at the address specified in the BDS; bear a statement “DO NOT OPEN BEFORE.....” the time and date for Bid opening as specified in the BDS.
- 21.5 If all or any envelopes are not sealed and marked as required by ITB Sub-Clause 21, the Employer **shall not reject the bids but assume no responsibility for the misplacement or premature opening of the Bid.**
- 22 Bid Submission Deadline
- 22.1 Bids must be received by the Employer at the address and no later than the date and time **specified in the BDS.**
- 22.2 Bids may be hand delivered, posted by registered mail or sent by courier.
- 22.2 The Employer may, at its discretion, extend the deadline for the submission of Bids by amending the Bidding Document in accordance with ITB Clause 7, in which case all rights and obligations of the Employer and Bidders previously subject to the deadline shall thereafter be subject to the new deadline as extended.
- 23 Late Bids
- 23.1 Late bids shall not be considered and shall be returned unopened
- 24 Modification, Substitution or Withdrawal of Bids
- 24.1 A Bidder may modify, substitute or withdraw their Bids after it has been submitted by sending a written notice before the deadline for submission of Bids.

- 25 Bid Opening
- 25.1 The Employer shall open the Bids in the presence of the bidders who is attending the bid opening, including modifications or substitutions made pursuant to ITB Clause 24. Bidders or their representatives shall be allowed to attend and witness the bid opening and shall sign a register evidencing their attendance.
- 25.2 The name of the Bidder, Bid modifications, substitutions or withdrawals, total amount of each Bid, number of corrections, discounts, and the presence or absence of requisite Bid Security, and such other details as the Employer, at its discretion, may consider appropriate, shall be read out aloud and recorded.
- 25.3 The Employer shall prepare minutes of the Bid opening. The minutes shall include, as a minimum, the name of the Bidders and whether there has been a withdrawal, substitution or modification; the Bid Price including any discounts and the presence or absence of a Bid Security, if one was required.
- 25.4 Bids not opened and read out at the Bid opening shall not be considered, irrespective of the circumstances, and shall be returned unopened to the Bidder

E. Tender Opening and Evaluation

- 26 Confidentiality
- 26.1 After the opening of Bids, information relating to the examination, clarification, and evaluation of Bids and recommendations for award shall not be disclosed to Bidders or other persons not officially concerned with the evaluation process until after the award of the Contract is announced.
- 27 Clarification
- 27.1 The Employer may ask Bidders for clarification of their Bids in order to facilitate the examination and evaluation of Bids. The request for clarification and the response shall be in writing, and any changes in the prices or substance of the Bid shall not be sought, offered or permitted, except to confirm the correction of arithmetical errors discovered by the Employer in the evaluation of the Bids, in accordance with ITB Clause 31.
- 28 Bidder: Contacting the Employer
- 28.1 Following the opening of Bids and until the Contract is signed no Bidder shall make any unsolicited communication to the Employer or try in any way to influence the Employer's examination and evaluation of Bids which may result in the rejection of bids. If any Bidder wishes to contact the Employer on any matter related to the Bidding process, it should do so in writing
- 29 Determination of Responsiveness
- 29.1 Prior to detailed evaluation of bids, the employer shall determine whether each bid (a) meets the eligibility criteria defined in ITB clause 3; (b) has been properly signed; (c) is accompanied by the bid security; and (d) is substantially responsive to the requirements of the bidding documents.
- 29.2 A substantially responsive Bid is one that conforms in all respects to the requirements of the Bidding Document without material deviation, reservation or omission. A material deviation, reservation or omission is one that:
- (a) affects in any substantial way the scope, quality, or

performance of the Works specified in the Contract; or

(b) limits in any substantial way, or is inconsistent with the Bid Document, the Employer's rights or the Bidder's obligations under the Contract; or

(c) if rectified would unfairly affect the competitive position of other Bidders presenting substantially responsive Bids.

29.3 If a Bid is not substantially responsive to the Bidding Document it shall be rejected by the Employer and shall not subsequently be made responsive by the Bidder by correction of the material deviation, reservation or omission.

29.4 There shall be no requirement as to the minimum number of responsive Bids.

30 Non Conformities, Errors and Omissions

30.1 The Employer may regard a Bid as responsive even if it contains minor deviations that do not materially alter or depart from the characteristics, terms, conditions and other requirement set forth in the Bidding Document or if it contains errors or oversights that are capable of being corrected without affecting the substance of the Bid.

31 Evaluation and Comparison of Tenders

31.1 The Employer shall evaluate and compare only those Bids determined to be substantially responsive to the requirements of the Bidding Document. Substantially responsive Bids are those which fulfil the requirements of ITB Clauses 11 and 12.

31.2 The evaluation will take into account corrected Bid Price and discounts (if any).

31.3 The Employer will check substantially responsive Bids for any arithmetical errors. Where there is a discrepancy between the amounts in figures and words, the amount in words will govern. If a Bidder refuses to accept the correction, its Bids shall be rejected. The Employer shall correct arithmetical errors on the following basis:

(a) if there is a discrepancy between the unit price and the line item total, the unit price shall prevail and the total price shall be corrected, unless in the opinion of the Employer there is an obvious misplacement of the decimal point in the unit price, in which case the total price, as quoted, shall govern and the unit price shall be corrected; and

32. Employer's Right to Accept or Reject any or all

32.1 The Employer reserves the right to accept any Bid, to annul the Bid proceedings, or to reject any or all Bids, at any time prior to Contract award, without thereby incurring any liability to Bidders, or any obligation to inform Bidders of the grounds for the Employer's actions.

F. Contract Award

33. Award Criteria

33.1 The Employer shall award the Contract to the Bidders whose offer is substantially responsive to the Bidding Document and that has been determined to be the lowest evaluated Bid, provided that the Bidder is determined to be qualified to perform the Contract satisfactorily

34. Letter of Intent to Award the Contract/
Notification of Award

- 34.1 The Employer shall notify the concerned Bidder whose bid has been selected in accordance with ITB 33.1 in writing (in the format in Section 4 hereafter called the "Letter of Intent to Award") that the Employer has intention to accept its bid and the information regarding the name, address and amount of selected bidder shall be given to all other bidders who submitted the bid. Such notification should be communicated in writing, including by cable, facsimile, telex or electronic mail to all the bidders on the same day of dispatch. The Employer shall ensure that the same information is uploaded on their website on the same day of dispatch.
- 34.2 If no bidder submits an application pursuant to ITB 35 within a period of ten (10) days of the notice provided under ITB 34.1, Prior to the expiration of the period of Bid validity, the Employer shall notify the successful Bidder, in writing that its Bid has been accepted. Until a formal contract is prepared and executed, the Notification of Award shall constitute a binding Contract.
- 34.3 Within fifteen (15) working days of the receipt of the Notification of Award from the Employer, the successful Bidder shall furnish the Performance Security, in the amount specified in the BDS.
- 34.4 The proceeds of the performance security shall be payable to the Employer unconditionally upon first written demand as compensation for any loss resulting from the Contractor's failure to complete its obligations under the Contract
- 34.5 Within fifteen (15) working days of receipt of the notification of award, the successful Bidder shall sign, date and return it to the Employer.

35. Complaints

- 35.1 The Bidder shall submit the complaint in writing within ten (10) days from the date of letter of intent to award the contract pursuant to ITB 34.1 to the Employer.
- 35.2 The Bidder may appeal to the Independent Review Body only if the Employer has not delivered the decision within the specified time, or the complainant is not satisfied with the decision of the Employer in accordance with rules and procedures of Independent Review Body.

Section 2 - Bidding Data Sheet

Instructions for completing the Bidding Data Sheet are provided, as needed, in the notes in italics mentioned for the relevant ITB Clauses

ITB Clause	Amendment of, and Supplements to, Clauses in the Instructions to Bidders
-------------------	---------------------------------------------------------------------------------

A. General

ITB 1.1	The Employer is <i>[Dzongda, Dzongkhag Administration, Tsirang]</i>
	The Name <i>[Construction of 4 unit toilet at Tsiringtoed central school]</i> and Identification of the Contract is <i>DAT/DES-10/2018-19/260 dated 15-02-2019.</i> The Works are <i>[Civil works: Earth works, RRM foundation, concrete brick work in superstructure, flooring, plastering, timber trusses, Pre-Painted Steel Corrugated Roofing, plinth, drainage, painting & storm water drainage]</i>
ITB 3.2	Option A: <i>Limited tender</i> All Bidders regardless of whether enlisted or not enlisted with the Dzongkhag may submit Bids provided they otherwise qualify.
ITB 3.3	The evaluation shall be based on the lowest price of the responsive bidder and the work will awarded to the lowest responsive bidder.

B. Bidding Documents

ITB 7.1	For <u>clarification of Tenders purposes</u> only, the Employer's address is: Attention: <i>Dzongkhag Engineer</i> Address: <i>Dzongkhag Administration, Tsirang</i> Telephone: <i>06-471202</i> Facsimile number: <i>06-471202</i>
----------------	------------------------------------------------------------------------------------------------------------------------------------------------------------------------------------------------------------------------------------------------------------------------------------

C. Preparation of Bids

ITB 15.1	The Bid validity period shall be [60] days.
ITB 15.2	A Bid Security in the amount of <i>Nu. 22,000.00/-</i> will be required, in the form; a) Unconditional Bank guarantee b) Cash warrant; or c) Demand draft
ITB 16.1	A simple bar chart is <i>required.</i>
ITB 19.1	In addition to the original, [<i>one</i>] copies shall be submitted.

D. Submission and Opening of Bids

ITB 17.2	The inner and outer envelopes shall bear the following additional identification marks: <i>[Do not open before 10:30 am on 27.02.2019]</i>
ITB 17.2	For <u>Bid submission purposes</u> only, the Employer's address is: Attention: <i>Dzongdag</i> Address: <i>Dzongkhag Administration, Tsirang</i> The deadline for the submission of Tenders is: <i>Time 10:00 AM, date; 27.02.2019.</i>
ITB 21.1	The Bid opening shall take place on the same day as the closing day of the bid submission at: <i>[Dzongkhag Conference Hall]</i> Date: <i>27/02/2019; Time: 10:30 AM.</i>

F. Award of Contract

ITB 34.2	The amount of Performance Security shall be <i>[10%]</i> percent of the Contract Price.
ITB 34.3	<p>The lowest evaluated bidder whose bid is considered abnormally low or unbalanced, following prescribed evaluation procedures, the bids shall be required to provide differential security in the form of “cash warrant” in addition to performance security. The cash warrant shall be valid for at least 6 months, and thereafter can be converted into bank guarantee. The payment has to be made within 15 working days after receipt of the letter of acceptance by the bidder.</p> <p>The additional security amount to be provided by the bidders, in the form of cash warrant shall be the difference between departmentally estimated amount and the amount quoted by the successful bidder less 20% of the departmentally estimated amount i.e</p>

Section 3 – Evaluation and Qualification Criteria

This section contains all the criteria that the Employer shall use to evaluate bids and qualify Bidders if the bidding was not preceded by a prequalification exercise and post qualifications are applied. Procuring Agency may apply basic minimum technical qualification requirement (manpower and equipment) only if there is a project specific need.

1. Evaluation

1.1 Evaluation shall be done to determine the responsiveness and the award shall be made to the lowest evaluated bidder.

Section 4: Forms of Bid & Qualification Information

Table of Standard Forms

Standard Form: Form of Bid

Standard Form: Letter of Intent

Standard Form: Letter of Acceptance

Standard Form: Bid security Bank
Guarantee

Standard Form: Form of bid

Date: -

To _____

Address _____

We offer to execute the contract for construction of “.....
.....” in accordance with the Conditions
of Contract accompanying this Bid for the Contract Price of
[*amount in figures*] (.....)
.....) [*amount in words*]
..... [*name of currency*].

The contract shall be paid in Ngultrums (Nu.)

This Bid and your written acceptance of it shall constitute a binding Contract between us. We understand that you are not bound to accept the lowest or any Bid you receive.

We hereby confirm that this Bid complies with the Bid validity and Bid Security required by the bidding documents and specified in the Bidding Data.

Authorized Signature: _____

(Affix Legal Stamp)

Name and Title of Signatory: _____

Name of Bidder: _____

Address: _____

Standard Form: Qualification Information

Notes on Form of Qualification Information: The following information is to be filled in by bidders which will be used for purposes of evaluation

1. Individual bidders

1.1 Constitution of legal status of Bidder [attach copy]

Place of registration:

Principal place of business:

Power of attorney of signatory of Bid [attach]

1.2 Qualifications and experience of key personnel proposed for administration and execution of the Contract. Refer BDS. The supporting documents such detailed CVs signed in original supported by certificates for qualification and experience.

Position	Name	Qualification & year of experience (general)	Year of experience in proposed position	Remarks
Site Supervisor				

Standard Form: Letter of Intent

(Letterhead paper of the Employer)

Notes on standard form of letter of Intent

This issuance of Letter of Intent (always before letter of acceptance) is the information of the selection of the bid of the successful bidder by the Employer and for providing information to other unsuccessful bidders who participated in the bid as regards the outcome of the procurement process

The Employer shall allow 10 days as described in ITB 34.2 between this letter of intent and letter of acceptance to allow aggrieved bidders to challenge your decision if they feel they have treated unfairly.

(Insert date)

To:-----[Name and address of the Contractor]

This is to notify you that, it is our intention to award the contract for your Bid dated-----
---[Insert date] for execution of the-----
-----[Insert name of the contract and identification number, as given in the BDS/SCC] for
the Contract Price of-----
-----[Insert amount in figure and words and name of currency] as corrected and modified[if
any corrections] in accordance with the Instructions to Bidders.

Authorized Signature: -----

Name and Title of Signatory:-----

Name of Agency:-----

CC:

[Insert name and address of all other bidders who submitted the bid]

Standard Form: Letter of Acceptance

[letterhead paper of the Employer]

Notes on Standard Form of Letter of Acceptance

The Letter of Acceptance will be the basis for formation of the Contract as described in Clauses 31 and 32 of the Instructions to Bidders. This Standard Form of Letter of Acceptance should be filled in and sent to the successful Bidder only after evaluation of bids has been completed.

[date] _____

To: _____

[name of the Contractor]

[address of the Contractor]

This is to notify that your Bid dated _____ for the execution of the contract for the construction of “_____ - _____” for the Contract Price _____ [amount in numbers] _____ [amount in words] _____ [name of currency], as corrected and modified in accordance with the Instructions to Bidders is hereby accepted by our Agency. The start date of the project is _____. The completion date for whole of the works shall be _____.

You are hereby instructed to proceed with the execution of the said Works in accordance with the Contract documents.

Authorized Signature:

Name and Title of Signatory:

Name of Agency:

Attachment: Agreement

Bank Guarantee for Bid Security

[this is the format for the Bid Security to be issued by a financial institutions in Bhutan in accordance with ITB Clause 19]

Invitation for Bid No:

Date:

Bid Package No:

To:

[Name and address of Employer]

TENDER GUARANTEE No:

We have been informed that *[name of Bidder]* (hereinafter called “the Bidder”) intends to submit to you its Bid dated *[date of bid]* (hereinafter called “the Tender”) for the execution of the Works of *[description of works]* under the above Invitation for Bids (hereinafter called “the IFB”).

Furthermore, we understand that, according to your conditions Bids must be supported by a Bid Guarantee.

At the request of the Bidder, we *[name of bank]* hereby irrevocably undertake to pay you, without cavil or argument, any sum or sums not exceeding in total an amount of Nu *[insert amount in figures and words]* upon receipt by us of your first written demand accompanied by a written statement that the Bidder is in breach of its obligation(s) under the Bid conditions, because the Bidder:

- (a) has withdrawn its Bids during the period of Bid validity specified by the Bidder in the Form of Bid; or
- (b) does not accept the correction of errors in accordance with the Instructions to Bidders ITB; or
- (c) having been notified of the acceptance of the Bid by the Employer during the period of Bid validity, (i) fails or refuses to furnish the performance security in accordance with the ITT, or (ii) fails or refuses to execute the Contract Form,

This guarantee will expire

- (a) if the Bidder is the successful Bidder, upon our receipt of a copy of the Performance Security and a copy of the Contract signed by the Bidder as issued by you; or
- (b) if the Bidder is not the successful Bidder, thirty days after the expiration of the Bidder’s Tender validity period, being *[date of expiration of the Tender]*.

Consequently, we must receive at the above-mentioned office any demand for payment under this guarantee on or before that date.

Signature

Signature

Section 5. General Conditions of Contract

1. Definitions

1.1 The following words and expressions shall have the meaning hereby assigned to them. Boldface type is used to identify the defined terms:

- (a) **Completion Certificate** means the Certificate issued by the Employer as evidence that the Contractor has executed the Works in all respects as per drawing, specifications, and Conditions of Contract.
- (b) The **Completion Date** is the date of completion of the Works as certified by the Engineer, in accordance with GCC Clause 18.
- (c) **Contract** means the Agreement entered into between the Employer and the Contractor to execute, complete and maintain the Works.
- (d) **Contractor** means the person or corporate body whose Tender to carry out the Works has been accepted by the Employer and is named as such in the SCC.
- (e) **Contract Price** is the price stated in the Letter of Acceptance and thereafter as adjusted in accordance with the provisions of the Contract. The **Contractor's Bid** is the completed Bid Document including the priced offer submitted by the Contractor to the Employer.
- (f) **Days** mean calendar days.
- (g) A **Defect** is any part of the Works not completed in accordance with the Contract.
- (h) The **Employer** is the party named in the SCC who employs the Contractor to carry out the Works.
- (i) The **Engineer** is the person named in the SCC, who is responsible for supervising the execution of the works and administering the Contract.
- (j) The **Intended Completion Date** is the date specified in the SCC on which the Contractor shall complete the Works and may be revised if extension of time or an acceleration order is issued by the Engineer.
- (k) The **Site** is the area defined as such in the SCC.
- (l) The **Works** are what the Contract requires the Contractor to construct, install, and hand over to the Employer, as defined in the SCC.

2. Interpretation & Documents forming the Contract

2.1 In interpreting the GCC, singular also means plural, male also means female or neuter, and the other way around. Headings in the GCC shall not be deemed part thereof or be taken into consideration in the interpretation or construance of the Contract. Words have their normal meaning under the language of the Contract unless

specifically defined.

2.2 The following documents forming the Contract shall be interpreted in the following order of priority:

- (a) the signed Contract Agreement.
- (b) the letter of Notification of Award.
- (c) the completed Bid form as submitted by the Bidder.
- (d) the Special Conditions of Contract.
- (e) the General Conditions of Contract.
- (f) Specifications
- (g) the Drawings.
- (h) any other document listed in the PCC as forming part of the Contract.

3. Corrupt,
Fraudulent,
Collusive or
Coercive Practices

3.1 The Government requires that Employers, as well as Contractors shall observe the highest standard of ethics during the implementation of procurement proceedings and the execution of Contracts under public funds.

3.2 In pursuance of this requirement, the Employer shall

- (a) exclude the Contractor from participation in the procurement proceedings concerned or reject a proposal for award; and
- (b) declare a Contractor ineligible, either indefinitely or for a stated period of time, from participation in procurement proceedings under public fund;

3.3 The Government defines, for the purposes of this provision, the terms set forth below as follows:

- (a) corrupt practice⁵ is the offering, giving, receiving or soliciting, directly or indirectly, of anything of value⁶ to influence improperly the actions of another party;
- (b) “fraudulent practice”⁷ is any intentional act or omission, including a misrepresentation, that knowingly or recklessly misleads, or attempts to mislead, a party to obtain a financial or other benefit or to avoid an obligation;
- (c) “collusive practice”⁸ is an arrangement between two or more parties designed to achieve an improper purpose, including to influence improperly the actions of another party; and
- (d) “coercive practice”⁹ is impairing or harming, or threatening to impair or harm, directly or indirectly, any party or the property of the party to influence improperly

the actions of a party.

- 3.4 The Government requires that the Client's personnel have an equal obligation not to solicit, ask for and/or use coercive methods to obtain personal benefits in connection with the said proceedings.
4. Governing Language and Law 4.1 The Contract as well as all correspondence and documents relating to the Contract exchanged by the Contractor and the Employer, shall be written in English unless otherwise stated in the SCC. The Contract shall be governed by and interpreted in accordance with the laws of the Kingdom of Bhutan.
5. Engineer's Decision 5.1 Except where otherwise specifically stated in the SCC, the Engineer will decide Contractual matters between the Employer and the Contractor in the role as representative of the Employer.
6. Delegation 6.1 The Engineer may delegate any of his duties and responsibilities to his representative, after notifying the Contractor, and may cancel any delegation, without retroactivity, after notifying the Contractor.
7. Communications and Notices 7.1 Communications between Parties pursuant to the Contract shall be in writing to the address specified in the SCC. A notice shall be effective when delivered or on the notice's effective date, whichever is later.
8. Sub- Contracting 8.1 The Contractor shall not be permitted to subcontract any part of the Works in whole or in part.
9. Contractor's Personnel 9.1 The Contractor shall employ the key personnel named in the Schedule of Key Personnel, as referred to in the SCC, to carry out the functions stated in the Schedule, or other personnel approved by the Engineer.
10. Welfare of Labourers & Child Labour 10.1 The Contractor shall provide proper accommodation to his labourers and arrange proper water supply, conservancy and sanitation arrangements at the site in accordance with relevant regulations, rules and orders of the government.
- 10.2 The Contractor shall comply with the applicable minimum age, labour laws and requirements of (including applicable treaties which have been ratified by) the Government of Bhutan regarding hazardous forms of child labour.
11. Safety, Security and Protection of the Environment 11.1 The Contractor shall throughout the execution and completion of the Works and the remedying of any defects therein :
- (a) have full regard for the safety of all persons entitled to be upon the Site and keep the Site and the Works in an orderly state;
- (b) provide and maintain at the Contractors own cost all lights, guards, fencing, warning signs and watching for the protection of the Works or for the safety on-site; and
- (c)take all reasonable steps to protect the environment on and off the Site and to avoid damage or nuisance to persons or to property of the public or others resulting from pollution, noise or other causes arising as a consequence of the Contractors methods of operation.
12. Access to the Site 12.1 The Contractor shall allow the Engineer and any person authorised by the Engineer access to the Site and to any place where work in connection with the Contract is being carried out or is intended to be

carried out.

- | | | |
|-----------------------------|------|-------------------------------------------------------------------------------------------------------------------------------------------------------------------------------------------------------------------------------------------------------------------------------------------------------------------------------------------|
| 13. Documents, Information. | 13.1 | The Contractor shall furnish to the Engineer all information, schedules, calculations and supporting documentation that may be requested of it. |
| 14. Property | 14.1 | If the contract is terminated by the Employer because of the contractors default, then, the contractor shall not be allowed to remove any materials on the Site, Plant, and Temporary Works until the matter is amicably resolved. |
| 15. Insurance | 15.1 | The Contractor shall provide insurance as stated in the SCC |
| | 15.2 | The Contractor shall deliver policies and certificates of insurance to the Engineer, for the Engineer's approval, before the Start Date. |
| | 15.3 | If the Contractor does not provide any of the policies and certificates required, the Employer may effect the insurance which the Contractor should have provided and recover the premiums the Employer has paid from payments otherwise due to the Contractor or, if no payment is due, the payment of the premiums shall be a debt due. |
| 16. Possession of the Site | 16.1 | The Employer shall give possession of the Site, or parts of the Site, to the Contractor on the date(s) specified in the SCC. |
| 17. Commencement of Works | 17.1 | The Contractor may commence execution of the Works on the Start Date, or other such date as specified in the SCC, and shall carry out the Works in an expeditious manner. |
| | 17.2 | If the Contractor fails to commence the works within the above stated period, the Employer may, at his sole discretion, terminate the Contract and forfeit the Performance Security, if any. |
| 18. Completion of Works | 18.1 | The Contractor shall complete the Works within the number of days stated in the SCC from the date of commencing the Works on the Site. |
| 19. Programme of Works | 19.1 | Within the time stated in the SCC, the Contractor shall submit to the Engineer for approval a work program. The Contractor shall submit to the Engineer for approval an updated Programme at intervals no longer than the period stated in the SCC. |
| 20. Early Warning | 20.1 | The Contractor shall warn the Engineer at the earliest opportunity of specific likely future events or circumstances that may adversely affect the quality of the work result in increase to the Contract Price or delay in the execution of the Works. |
| 21. Compensation Events | 21.1 | The following shall be Compensation Events:
(a) the Employer does not give access to the Site or part of the Site by the Site Possession Date stated in the SCC; and
(b) if the payment is delayed pursuant to Clause 25.1. |
| | 21.2 | If a Compensation Event would prevent the work being completed before the Intended Completion Date, the Intended Completion Date shall be extended, as appropriate, by the Engineer. |

- | | | |
|----------------------------------|------|-----------------------------------------------------------------------------------------------------------------------------------------------------------------------------------------------------------------------------------------------------------------------------------------------------------------------------------------------------------------------------------------------|
| 22. Non-Scheduled Items of Works | 22.1 | The Contractor shall be paid for non-scheduled items of works only when the Engineer approves such works and at the rates and in the manner stated in the SCC. |
| 23. Schedule of Works | 23.1 | The Schedule of Works will contain rates for all items for the construction including temporary works, installation, testing, and commissioning work to be done by the Contractor. |
| | 23.2 | The Contractor shall be paid for the quantity of the work done at the rate in the Contract Agreement for each item. |
| | 23.3 | The Contractor shall be entirely responsible for all taxes, duties, license fees, and other such levies imposed outside and inside Bhutan. |
| 24. Payment Certificates | 24.1 | The Contractor shall submit to the Engineer monthly statements of the estimated value of the work executed less the cumulative amount certified previously. The Engineer shall check the Contractor's monthly statement and certify the amount to be paid to the Contractor. |
| | 24.2 | The value of work executed shall be determined by the Engineer. |
| | 24.3 | The value of work executed shall comprise the value of the quantities of the items in the Schedule of Works completed. |
| | 24.4 | The value of work executed shall include the valuation of Variations, Certified Day works and Compensation Events. |
| | 24.5 | The Engineer may exclude any item certified in previous certificates or reduce the proportion of any item previously certified in any certificate in the light of later information. |
| 25. Payments and Currency | 25.1 | The Employer shall pay the Contractor the amounts certified by the Engineer within thirty (30) days of the date of each certificate. |
| | 25.2 | The Employer shall make Advance Payment (mobilization and secured advance) to the Contractor of the amounts and by the dates stated in the SCC against provision by the Contractor of an unconditional Bank Guarantee, (Form 4). |
| | 25.3 | The Contractor is to use the advance payment only to pay for Equipment, Plant, Materials, and mobilisation expenses required specifically for the execution of the Contract. The Contractor shall demonstrate that the advance payment has been used in this way by submitting copies of invoices or other documents to the Employer. |
| | 25.4 | The advance payment shall be repaid by deducting proportionate amounts from payments otherwise due to the Contractor, following the schedule of completed percentages of the Works on a payment basis. No account shall be taken of the advance payment or its repayment in assessing valuations of work done, variations, claims or any amount payable due to failure to complete the works. |
| 26. Retention | 26.1 | The Employer shall retain from each payment due to the Contractor the proportion stated in the SCC until the completion of the whole of the Works. |
| | 26.2 | On completion of the whole of the Works, half the total amount retained shall be repaid to the Contractor, the remaining half when the Defects Liability Period has passed and the Engineer has certified that all Defects notified by the Engineer to the Contractor |

before the end of this period have been corrected.

- | | | |
|---------------------------|------|------------------------------------------------------------------------------------------------------------------------------------------------------------------------------------------------------------------------------------------------------------------------------------------------------------------------|
| 27. Liquidated Damages | 27.1 | The Contractor shall pay liquidated damages to the Employer at the rate per day stated in the SCC for each day that the Completion Date is later than the Intended Completion date for the works or for any part thereof. |
| 28. Performance Security | 28.1 | Upon Notification of Award, a Performance Security shall be provided to the Employer in the amount and form stated in the Contract Forms (Form 3). The Performance Security shall be valid until a date thirty (30) days from the date of issue of the Certificate of Completion. |
| 29. Price Adjustment | 29.1 | The rates and prices in the bill of quantities are fixed for the duration of the Contract and not subject to price adjustment during the performance of the Contract. |
| 30. Completion | 30.1 | The Contractor shall request the Engineer to issue a Certificate of Completion of the Works, and the Engineer will do so upon deciding that the work is substantially completed. |
| 31. Correction of Defects | 31.1 | The Engineer shall give notice to the Contractor of any Defects before the end of the Defects Liability Period, which begins at Completion, and is defined in the SCC. The Defects Liability Period shall be extended for as long as the Defects remain to be corrected. |
| | 31.2 | If the Contractor has not corrected a Defect within the time specified in the Engineer's notice, the Engineer will assess the cost of having the Defect corrected, and the Contractor will pay this amount. |
| 32. Taking Over | 32.1 | The Employer shall take over the Site and the Works within seven (7) days of the Engineer issuing a Certificate of Completion. |
| 33. Final Account | 33.1 | The Contractor shall supply the Engineer a detailed account of the total amount that the Contractor considers payable under the Contract. The Engineer shall certify any final payment that is due to the Contractor within twenty-one (21) days of receiving the Contractor's account if it is correct and complete. |
| | 33.2 | The Employer shall effect payment of the final account within thirty (30) days from the date of certification by the Engineer. |
| 34. Termination | 34.1 | The Employer or the Contractor by giving thirty (30) days written notice of default to the other party, may terminate the Contract in whole or in part if the other party causes a fundamental breach of Contract. |
| | 34.2 | Fundamental breaches of the Contract shall include, but shall not be limited to, the following:
<ul style="list-style-type: none">(a) the Contractor stops work for more than thirty (30) days when no stoppage of work is shown on the current Programme and the stoppage has not been authorised by |

the Engineer;

- (b) the Engineer gives notice that failure to correct a particular defect is a fundamental breach of Contract and the Contractor fails to correct it within a reasonable period of time determined by the Engineer;
- (c) the Contractor has delayed the completion of the Works by the number of days for which the maximum amount of Liquidated Damages can be paid;
- (d) the Contractor, in the judgment of the Employer, has engaged in corrupt or fraudulent practices, as defined in GCC Clause 3, in competing for or in executing the Contract; and
- (e) a payment certified by the Engineer is not paid to the Contractor by the Employer within sixty (60) days of the date of the Engineer's certificate.

34.3 The Employer and the Contractor may at any time terminate the Contract by giving notice to the other party if either of the parties becomes bankrupt or otherwise insolvent. In such event, termination will be without compensation to any party provided that such termination will not prejudice or affect any right of action or remedy that has accrued or will accrue to the other party.

34.4 Notwithstanding the above, the Employer may terminate the Contract for convenience.

34.5 If the Contract is terminated, the Contractor is to stop work immediately, make the Site safe and secure and hand over the Site to the Employer as soon as reasonably possible.

35. Payment upon Termination

35.1 If the Contract is terminated because of a fundamental breach of Contract by the Contractor, the Engineer shall issue a certificate for the value of the work done and Plant and Materials ordered less advance payments received up to the date of the issue of the certificate and less the percentage to apply to the value of the work not completed, as indicated in the SCC.. Additional Liquidated Damages shall not apply. If the total amount due to the Employer exceeds any payment due to the Contractor, the difference shall be a debt payable to the Employer.

35.2 If the Contract is terminated for the Employer's convenience or because of a fundamental breach of Contract by the Employer, the Contractor shall be entitled to payments for completed works and the materials that have been brought to the site for the purpose of the works, but not used as certified by the Engineer after adjusting any payments received by the Contractor.

36. Release from Performance

36.1 If the Contract is frustrated by the outbreak of war or by any other event entirely outside the control of either the Employer or the Contractor, the Engineer shall certify that the Contract has been frustrated. The Contractor shall make the Site safe and stop work as quickly as possible, after receiving this certificate. The Contractor shall be paid for all works carried out before stoppage of work and any work carried out afterwards to which a commitment was made.

37. Force Majeure

37.1 For the purposes of this Contract, "Force Majeure" means an exceptional event or circumstance:

- (a) which is beyond a Party's control,
- (b) which such Party could not reasonably have provided against before entering into the Contract,
- (c) which, having arisen, such Party could not reasonably have avoided or overcome, and
- (d) which is not substantially attributable to the other Party.

37.2 Force Majeure may include, but is not limited to, exceptional events or circumstances of the kind listed below, so long as conditions (a) to (d) above are satisfied:

- (a) war, hostilities (whether war be declared or not), invasion, act of foreign enemies,
- (b) rebellion, terrorism, sabotage by persons other than the Contractor's Personnel, revolution, insurrection, military or usurped power, or civil war,
- (c) riot, commotion, disorder, strike or lockout by persons other than the Contractor's Personnel,
- (d) munitions of war, explosive materials, ionizing radiation or contamination by radio-activity, except as may be attributable to the Contractor's use of such munitions, explosives, radiation or radio-activity, and
- (e) natural catastrophes such as earthquake, hurricane, typhoon or volcanic activity.

37.3 However, force majeure shall not include the following;

- i. rainfall
- ii. snowfall
- iii. strikes in other countries
- iv. non-availability of labourer and materials such as timbers, boulders, sand, and other materials
- v. difficulty and risky terrain and remoteness of site.

38. Settlement of Disputes

38.1 The Employer and the Contractor shall use their best efforts to settle amicably all disputes arising out of or in connection with this Contract or its interpretation.

38.2 Any dispute between the parties to the Contract that may not be settled amicably will be referred to Arbitration at the initiative of either of the parties.

38.3 The Arbitration shall be conducted in accordance with the Arbitration Rules of the Kingdom of Bhutan in force.

Section 6. Special Conditions of Contract	
<i>Instructions for completing the Special Conditions of Contract are provided, as needed, in the notes in italics mentioned for the relevant GCC Clauses.3</i>	
Clause Ref	Amendments of, and Supplements to, Clauses in the General Conditions of Contract
GCC 1.1(d)	The Contractor is [<i>name :</i> <i>Address.....</i> <i>and name of authorised representative.....</i>].
GCC 1.1(i)	The Employer is: - <i>Dzongdag, Dzongkhag Administration, Tsirang</i>
GCC 1.1(j)	The Engineer is [<i>Prem Bdr. Ghalley Dzongkhag Engineering section Tsirang-17692372</i>]
GCC 1.1(k)	The Intended Completion Date for the whole of the Works shall be [<i>3 months</i>].
GCC 1.1(l)	The Site is located at [<i>Tsiringtoed CS</i>].
GCC 1.1(m)	The Works are [<i>Earth works, RRM foundation, concrete brick work in superstructure, flooring, plastering, timber trusses, Pre-Painted Steel Corrugated Roofing, plinth, drainage, painting & storm water drainage</i>]
GCC 2.2(i)	The additional documents forming part of this Contract are: <ol style="list-style-type: none"> 1. Valid Trade Licence. 2. Valid CDB Certificate. 3. Valid Tax clearance.
GCC 4.1	The Language governing the Contract shall be [<i>English</i>].
GCC 5.1	The Engineer shall obtain specific approval of the Employer before taking any of the following actions: <ul style="list-style-type: none"> • Additional work • Change in design & specification • Site location
GCC 7.1	The addresses for Communications shall be: <u>For the Employer:</u> <i>Dzongdag, Dzongkhag Administration, Tsirang</i> <u>For the Contractor:</u>
GCC 9.1	The Key Personnel of the Contractor are: [<i>site supervisor</i>]

GCC 15.1	For insurance purposes, the type of cover required shall be: The contractor shall be responsible for the insurance.
GCC 16.1	Possession of the site shall be within [5] days from the date of signing of the Contract.
GCC 17.1	Commencement of work shall be within 7 days . However, the actual start date of contract duration shall be indicated in the 'Letter of Acceptance'
GCC 18.1	Completion of works shall be within Completion of works from the date of commencing the works on the site shall be within the date as indicated in the 'Letter of Acceptance'
GCC 19.1 & 19.2	The Contractor shall submit the first work plan on the date of signing the Contract, and shall update the work plan every [2] weeks during the period of the Contract.
GCC 22.1	<i>"The rates for non-scheduled items of works shall be determined by the Engineer" & should be endorsed by the DTC.</i>
GCC 25.2	An advance payment of [10] % of the Contract Price will be made to the Contractor within (14) days of Contract signing date.
GCC 26.1	The Retention shall be [10] % of the Contract Price.
GCC 27.1	The liquidated damages for the whole of the Works are [0.05 %] per day. The maximum amount of liquidated damages for the whole of the Works is [10 %] percent of the initial Contract Price.
GCC 31.1	The Defects Liability Period shall be [12] (<i>twelve months</i>).
GCC 35.1	The percentage to apply to the value of the work not completed, representing the Employer's additional cost for completing the Works, is [20% of the value of work not completed up to a maximum of 10% of the initial contract price]
GCC 36.1	The lowest evaluated bidder whose bid is considered abnormally low or unbalanced, following prescribed evaluation procedures, the bids shall be required to provide differential security in the form of " cash warrant " in addition to performance security. The cash warrant shall be valid for at least 6 months, and thereafter can be converted into bank guarantee. The payment has to be made within 15 working days after receipt of the letter of acceptance by the bidder.

Section 7 – Contract Forms

This section contains forms which, once completed, will form part of the Contract. The forms for Performance Security and Advance Payment Security, when required, shall only be completed by the successful Bidder after Contract award.

Contract Forms

Form	Title
Form -1	Notification of Award
Form -2	Contract Agreement
Form -3	Bank Guarantee for Performance Security
Form -4	Bank Guarantee for Advance Payment

Notification of Award

Contract No:

Date:

To:

[name and address of Contractor]

This is to notify you that your Bid dated *[insert date]* for the execution of the Works for *[name of project / Contract]* for the Contract Price of Nu *[amount in figures and in words]*, as corrected and modified in accordance with the Instructions to bidder is hereby accepted by *[name of the Employer]*.

You are requested to proceed with the execution of the Works on the basis that this Notification of Award shall constitute the formation of a Contract, which shall become binding upon you furnishing a Performance Security within fourteen (14) days, in accordance with ITB Clause 32, and the signing the Contract Agreement within twenty-one (21) days, in accordance with ITB Clause 33.

We attach the Contract Agreement and Special Conditions of Contract for your perusal and signature.

Signed

Duly authorised to sign for and on behalf of
[name of Procuring Entity]

Date:

Contract Agreement

THIS AGREEMENT, made the [day] of [month] [year] between [name and address of Employer] (hereinafter called “the Employer”) of the one part and [name and address of Contractor] (hereinafter called “the Contractor”) of the other part.

WHEREAS, the Employer invited Tenders for certain Works, viz, [brief description of the Works] and has accepted a Tender by the Contractor for the execution of those works in the sum of Ngultrum [insert amount in figures and words], hereinafter called “the Contract Price.

NOW THIS AGREEMENT WITNESSETH as follows:

1. In this Agreement, words and expressions shall have the same meanings as are respectively assigned to them in the General Conditions of Contract hereinafter referred to.
2. The documents forming the Contract shall be interpreted in the following order of priority:
 - (a) The signed Contract Agreement;
 - (b) The letter of Acceptance;
 - (c) The completed Bid form as submitted by the Bidder;
 - (d) The Special Conditions of Contract;
 - (e) The General Conditions of Contract;
 - (f) Specifications
 - (g) The Drawings; and
 - (h) Any other document listed in the SCC as forming part of the Contract..
3. In consideration of the payments to be made by the Employer to the Contractor as hereinafter mentioned, the Contractor hereby covenants with the Employer to execute and complete the Works and to remedy any defects therein in conformity in all respects with the provisions of the Contract.
4. The Employer hereby covenants to pay the Contractor in consideration of the execution and completion of the Works and the remedying of defects therein, the Contract Price or such other sum as may become payable under the provisions of the Contract at the times and in the manner prescribed by the Contract.

IN WITNESS whereof the Parties thereto have caused this Agreement to be executed in accordance with the laws of Bhutan on the day month and year first before written.

For the Employer

For the Contractor

Signature

Print Name

Title

In the presence
of (Name)

Address

Bank Guarantee for Performance Security

[this is the format for the Performance Security to be issued by any financial institute in Bhutan in accordance with ITB Clause 35]

Contract No:

Date:

To:

[Name and address of Employer]

PERFORMANCE GUARANTEE No:

We have been informed that *[name of Contractor]* (hereinafter called “the Contractor”) has undertaken, pursuant to Contract No *[reference number of Contract]* dated *[date of Contract]* (hereinafter called “the Contract”), the execution of works *[description of works]* under the Contract.

Furthermore, we understand that, according to your conditions, Contracts must be supported by a performance guarantee.

At the request of the Contractor, we *[name of bank]* hereby irrevocably undertake to pay you, without cavil or argument, any sum or sums not exceeding in total an amount of Nu *[insert amount in figures and in words]* upon receipt by us of your first written demand accompanied by a written statement that the Contractor is in breach of its obligation(s) under the Contract conditions, without you needing to prove or show grounds or reasons for your demand of the sum specified therein.

This guarantee is valid until *[date of validity of guarantee]*, consequently, we must receive at the above-mentioned office any demand for payment under this guarantee on or before that date.

Signature

Signature

Bank Guarantee for mobilisation advance

[this is the format for the Advance Payment Guarantee to be issued by a financial institutions in Bhutan in their letter pad in accordance with SCC Clause 25.2]

Contract No:

Date:

To:

[Name and address of Employer]

ADVANCE PAYMENT GUARANTEE No:

We have been informed that *[name of Contractor]* (hereinafter called “the Contractor”) has undertaken, pursuant to Contract No *[reference number of Contract]* dated *[date of Contract]* (hereinafter called “the Contract”), the execution of works *[description of works]* under the Contract.

Furthermore, we understand that, according to your conditions, Advance Payments must be supported by a bank guarantee.

At the request of the Contractor, we *[name of bank]* hereby irrevocably undertake to pay you, without cavil or argument, any sum or sums not exceeding in total an amount of Nu. *[insert amount in figures and in words]* upon receipt by us of your first written demand accompanied by a written statement that the Contractor is in breach of its obligation(s) under the Contract conditions, without you needing to prove or show grounds or reasons for your demand of the sum specified therein.

We further agree that no change, addition or other modification of the terms of the Contract to be performed, or of any of the Contract documents which may be made between the Employer and the Contractor, shall in any way release us from any liability under this guarantee, and we hereby waive notice of any such change, addition or modification.

This guarantee is valid until *[date of validity of guarantee]*, consequently, we must receive at the above-mentioned office any demand for payment under this guarantee on or before that date.

Signature

Signature

Section 8 Bill of Quantities (BoQ)

Name: - Construction of 4 unit toilet-1 at Tsiringtoed Central School.

Subject : - Bill of Quantity

Sl No	BSR Code	Description of item	Qty	Unit	Rate in		Amount
					figure	Words	
1	EW0030	Earth work in excavation over areas, depth >300mm, width >1.5m, area >10 Sq.m on plan, including disposal of excavated earth within 50m lead and 1.5m lift & disposed soil to be neatly dressed Ordinary Soil	54.00	Cu.m			
2	EW0105	Excavation in foundation trenches or drains not exceeding 1.5m in width or area 10 sq.m on plan, including dressing & ramming, disposal of surplus soil within 50m lead & 1.5m lift Ordinary Soil	25.45	Cu.m			
3	EW0195	Filling of trenches, sides of foundations etc. in layers <200mm using selected excavated earth, ramming etc. within lead 50 m & lift 1.5m	4.56	Cu.m			
4	SM0072	Providing and laying Hand packed stone filling or soling with stones	3.83	Cu.m			
5	CW0003	Providing and laying in position plain cement concrete excluding the cost of centering and shuttering - All work up to plinth level. 1:2:4 (1 cement: 2 sand: 4 graded crushed rock 20 mm nominal size)	4.21	Cu.m			
6	SM0006	Providing & laying Random Rubble Masonry with hard stone in foundation & plinth in cement mortar 1:5	11.63	Cu.m			
7	BW0152+ BW0172	Providing & laying concrete block brick in superstructure above plinth level, up to floor two level in cement mortar 1:5	8.31	Cu.m			
8	BW0199	Providing & laying Concrete Solid Block Masonry (125 mm) in superstructure below floor 2 level in CM 1:4 for the partation walls.	8.46	Sq.m			

Name: - Construction of 4-unit toilet-1 at Tsiringtoed Central School.

Subject: - Bill of Quantity

<i>Sl No</i>	<i>BSR Code</i>	<i>Description of item</i>	<i>Qty</i>	<i>Unit</i>	<i>Rate in</i>		<i>Amount</i>
					<i>figure</i>	<i>Words</i>	
9	RC0083	Providing & fixing Thermo-Mechanically Treated reinforcement bar (Yield Strength 500 MPa) for R.C.C work including cutting, bending, binding and placing in position complete as per the drawing. 10mm.	39.11	Kg			
10	RC0003	Providing & laying in position reinforced cement concrete excluding the cost of centering, shuttering and reinforcement - all work up to plinth level 1:2:4 (1 cement: 2 sand : 4 graded crushed rock 20 mm nominal size).	0.02	Cu.m			
11	WW0055	Providing & fixing Mixed Conifer (undressed) in wall-frames etc.wall plate & for fixing of plywood	0.38	Cu.m			
12	WW0060	Providing & fixing roof framing, in trusses, purlins, rafters, posts, post plates including hoisting, etc. (excluding steel items) Mixed Conifer	0.50	Cu.m			
13	WW0030	Providing & fixing Eaves board (225x25mm) with moulding fitted and fixed with necessary screws Mixed Conifer	24.36	m			
14	WW0132	Providing & fixing Plywood lining with necessary nails etc. including beading complete (excluding cost of frame) 6 mm, commercial.	20.84	Sq.m			
15	RF0003	Providing & fixing Pre Painted Steel Corrugated Roofing sheets, including bolts, hooks and nuts 8mm dia. with bitumen and G.I limpet washers filled with white lead for connection, excluding the cost of purlins, rafter and trusses. 25g (0.50mm).	39.60	Sq.m			

Name: - Construction of 4 unit toilet-1 at Tsiringtoed Central School.

Subject : - Bill of Quantity

Sl No	BSR Code	Description of item	Qty	Unit	Rate in		Amount
					figure	Words	
16	DR0001	Providing and laying 50mm thick Plinth Protection and grouted with fine sand mix including well rammed, finishing the top smooth With cement concrete 1:3:6, 20mm aggregates, laid over 75mm thick layer of compacted gravel (40mm)	14.68	Sq.m			
17	DR0031	Constructing random rubble masonry open surface drain in cement mortar 1:6 including earth work in excavation, 100mm thick concrete base 1:5:10, 40 mm aggregate 25mm thick cement concrete 1:2:4, 12mm aggregate for filling haunches, including 20mm cement plaster with a floating coat of neat cement, disposal of surplus earth 200 x 150mm depth	32.10	m			
18	EW0197	Providing & laying dry earth bedding, including consolidating each deposited layer by watering, ramming and dressing	2.70	Cu.m			
19	FL0052	Pal cement concrete flooring 1:2:4, finished with floating coat of neat cement 20mm aggregates, 50mm thick.	10.80	Sq.m			
20	PL0040	Providing & laying 20mm cement plaster C.M 1:3 external wall	36.69	Sq.m			
21	PL0020	Providing & laying 12mm cement plaster inner wall C.M 1:3.	18.13	Sq.m			
22	PL0070	Providing & laying cement plaster, finished with floating coat of neat cement 12mm plaster in C.M 1:3 height up to 1.5m from the floor level.	29.83	Sq.m			

Name: - Construction of 4 unit toilet-1 at Tsiringtoed Central School.

Subject : - Bill of Quantity

<i>Sl No</i>	<i>BSR Code</i>	<i>Description of item</i>	<i>Qty</i>	<i>Unit</i>	<i>Rate in</i>		<i>Amount</i>
					<i>figure</i>	<i>Words</i>	
23	PL0072	Providing & laying cement plaster, finished with floating coat of neat cement 20mm plaster in C.M 1:3 for plinth band external	11.58	Sq.m			
24	PT0042	Providing and applying finishing coats Acrylic washable distemper, two coats on new work, including cement primer coat. Internal wall painting.	18.13	Sq.m			
25	PT0052	Providing and applying finishing coats Vinyl plastic emulsion paint, for cement, masonry, plaster,two coats on new work.	36.69	Sq.m			
26	PT0072	Providing and applying wood preservatives Coal tar, two coats on new work for the trusses.	1	L/s			
27	PT0112	Providing, preparing and applying Sumdang washable painting Thamar.	1	L/s			
28	PT0048	Providing and applying finishing coats High gloss synthetic enamel\for steel & wood work, two coats on new work.	24.50	Sq.m			
29	AR	P/F door type D-1 as per the drawing including MS hinges of 100mm,MS tower bolt of 100mm, MS sliding door bolt of 200mm & MS handle of 100mm excluding the painting works.	3.00	No.			
30	AR	P/F Window type W-1 as per the drawing including MS hinges of 75mm,MS tower bolt of 100mm, MS hook-and-eye of 100mm & MS handle of 75mm excluding the painting works.	3.00	No.			

Name: - Construction of 4-unit toilet-1 at Tsringtoed Central School.

Subject: - Bill of Quantity

Sl No	BSR Code	Description of item	Qty	Unit	Rate in		Amount
					figure	Words	
31	WW0630	Providing & fixing anodised aluminium kicking plate, 4mm thick with necessary aluminium screws etc. complete	4.59	Sq.m			
32	PI0001	Providing & fixing CPVC pipes including CPVC fittings & clamps & repair walls 15mm	20.00	m			
33	PO0640	Providing & laying H.D.P.E pipes, 6 PN, including H.D.P.E fittings, trenching & refilling 20mm.	25.00	m			
34	PI0041	Providing & fixing Indian-type vitreous china w.c squatting pan, including 100 mm H.C.I P or S trap, 10 lit low level vitreous china cistern & fittings, repair walls 580mm, white Orissa-model	3.00	Each			
35	PI0260	Providing & fixing toilet paper holder C.P. brass	3.00	Each			
36	PI0275	Providing & fixing soap dish including brackets, wooden cleats, c.p. brass screws	3.00	Each			
37	PI0205	Providing & fixing c.p. bibcock 15mm, standard vertical, c.p knob	3.00	Each			
38	PI0177	Providing & fixing C.P. Brass shower fittings Shower arm, standard 15mm.	3.00	Each			
39	PI0185	Providing & fixing c.p. brass stop cock 15mm, standard, c.p knob.	6.00	Each			
40	PO0565	Providing & fixing P.V.C Nahani Trap 110mm inlet & 75mm outlet	3.00	Each			
41		Providing & fixing P.V.C door bend					
	PO0415	75mm dia	3.00	Each			
	PO0417	110mm dia	3.00	Each			
42		Providing & fixing P.V.C plain bend					
	PO0405	75mm dia	3.00	Each			
	PO0417	110mm dia	5.00	Each			

Name: - Construction of 4 unit toilet-1 at Tsiringtoed Central School.

Subject : - Bill of Quantity

<i>Sl No</i>	<i>BSR Code</i>	<i>Description of item</i>	<i>Qty</i>	<i>Unit</i>	<i>Rate in</i>		<i>Amount</i>
					<i>figure</i>	<i>Words</i>	
43		Providing & fixing P.V.C soil waste and vent pipes, single or double socketed, including pipe clip complete (excluding the cost of PVC fittings)					
	PO0370	75mm dia	5.93	m			
	PO0372	110mm dia	10.00	m			
44	PI0087	Providing & fixing white vitreous china wash basin, including C.I brackets, 15mm C.P. brass pillar taps, c.p. chain & rubber plug, 32mm pvc waste, 32mm dia. trap & union, repair walls Flat back wash basin 550x400mm with a pair of 15mm c.p. brass pillar taps.	3.00	Each			
45	PI0115	Providing & fixing pedestals for basins, white vitreous china, recessed back for pipes and necessary fittings.	3.00	Each			
46	PI0253	Providing & fixing c.p. towel rail 600 x 20mm with c.p brass brackets fixed to wooden cleats	3	Each			
47	PI0250	Providing & fixing 600x450mm bevelled edge mirror (superior glass) incl.4mm A.C sheet base fixed to wooden cleats	3	Each			
48	PO0610	Constructing Septic Tanks, in R.R Masonry in cement mortar 1:6, including fittings, C.I cover with frame, 40mm thick concrete flooring (40mm aggregates) cement plaster concrete base in C.C 1:4:8 etc. complete as per standard design 25 users	1.00	Each			
49	PO0600	Size1200x1200x1200mm, filled with brick bats including 100mm SW drain pipe X 1200mm long	1.00	Each			
Total Amount for toilet-1(A) civil Nu.							

Name: - Construction of 4 unit toilet-2 at Tsiringtoed Central School.(Near Dzong)

Subject : - Bill of Quantity

Sl No	BSR Code	Description of item	Qty	Unit	Rate in		Amount
					figure	Words	
1	EW0030	Earth work in excavation over areas, depth >300mm, width >1.5m, area >10 Sq.m on plan, including disposal of excavated earth within 50m lead and 1.5m lift & disposed soil to be neatly dressed Ordinary Soil	45.00	Cu.m			
2	EW0105	Excavation in foundation trenches or drains not exceeding 1.5m in width or area 10 sq.m on plan, including dressing & ramming, disposal of surplus soil within 50m lead & 1.5m lift Ordinary Soil	25.45	Cu.m			
3	EW0195	Filling of trenches, sides of foundations etc. in layers <200mm using selected excavated earth, ramming etc. within lead 50 m & lift 1.5m	4.56	Cu.m			
4	SM0072	Providing and laying Hand packed stone filling or soling with stones	3.83	Cu.m			
5	CW0003	Providing and laying in position plain cement concrete excluding the cost of centering and shuttering - All work upto plinth level. 1:2:4 (1 cement: 2 sand: 4 graded crushed rock 20 mm nominal size)	4.21	Cu.m			
6	SM0006	Providing & laying Random Rubble Masonry with hard stone in foundation & plinth In cement mortar 1:5	11.63	Cu.m			
7	BW0152 + BW0172	Providing & laying concrete block brick in superstructure above plinth level, up to floor two level In cement mortar 1:5	8.31	Cu.m			
8	BW0199	Providing & laying Concrete Solid Block Masonry (125 mm) in superstructure below floor 2 level in CM 1:4 for the partation walls.	8.46	Cu.m			
9	RC0083	Providing & fixing Thermo-Mechanically Treated reinforcement bar (Yield Strength 500 MPa) for R.C.C work including cutting, bending, binding and placing in position complete as per the drawing. 10mm.	39.11	Kg.			

Name: - Construction of 4 unit toilet-2 at Tseringtoed Central School.(Near Dzong)

Subject : - Bill of Quantity

Sl No	BSR Code	Description of item	Qty	Unit	Rate in		Amount
					figure	Words	
10	RC0003	Providing & laying in position reinforced cement concrete excluding the cost of centering, shuttering and reinforcement - all work upto plinth level 1:2:4 (1 cement : 2 sand : 4 graded crushed rock 20 mm nominal size).	0.02	Cu.m			
11	WW0055	Providing & fixing Mixed Conifer (undressed) in wall-frames etc.wall plate & for fixing of plywood	0.38	Cu.m			
12	WW0060	Providing & fixing roof framing, in trusses, purlins, rafters, posts, post plates including hoisting, etc. (excluding steel items) Mixed Conifer	0.50	Cu.m			
13	WW0030	Providing & fixing Eaves board (225x25mm) with moulding fitted and fixed with necessary screws Mixed Conifer	24.36	M			
14	WW0132	Providing & fixing Plywood lining with necessary nails etc. including beading complete (excluding cost of frame) 6 mm, commercial.	23.14	Sq.m			
15	RF0003	Providing & fixing Pre Painted Steel Corrugated Roofing sheets, including bolts, hooks and nuts 8mm dia. with bitumen and G.I limpet washers filled with white lead for connection, excluding the cost of purlins, rafter and trusses. 25g (0.50mm).	35.80	Sq.m			
16	RF0007	Providing & fixing 600mm ridges or hips in Pre Painted Steel sheets, including bolts, hooks and nuts 8mm dia G.I limpet and bitumen washers for connection.	8.95	m			
17	DR0001	Providing and laying 50mm thick Plinth Protection and grouted with fine sand mix including well rammed, finishing the top smooth With cement concrete 1:3:6, 20mm aggregates, laid over 75mm thick layer of compacted gravel (40mm)	10.56	Sq.m			

Name: - Construction of 4 unit toilet-2 at Tsiringtoed Central School.(Near Dzong)

Subject : - Bill of Quantity

<i>Sl No</i>	<i>BSR Code</i>	<i>Description of item</i>	<i>Qty</i>	<i>Unit</i>	<i>Rate in</i>		<i>Amount</i>
					<i>figure</i>	<i>Words</i>	
18	DR0031	Constructing random rubble masonry open surface drain in cement mortar 1:6 including earth work in excavation, 100mm thick concrete base 1:5:10, 40 mm aggregate 25mm thick cement concrete 1:2:4, 12mm aggregate for filling haunches, including 20mm cement plaster with a floating coat of neat cement, disposal of surplus earth 200 x 150mm depth	32.10	m			
19	EW0197	Providing & laying dry earth bedding, including consolidating each deposited layer by watering, ramming and dressing	2.70	Cu.m			
20	FL0052	Pal cement concrete flooring 1:2:4, finished with floating coat of neat cement 20mm aggregates, 50mm thick.	10.80	Sq.m			
21	PL0040	Providing & laying 20mm cement plaster C.M 1:3 external wall	36.69	Sq.m			
22	PL0020	Providing & laying 12mm cement plaster inner wall C.M 1:3.	18.13	Sq.m			
23	PL0070	Providing & laying cement plaster, finished with floating coat of neat cement 12mm plaster in C.M 1:3 height up to 1.5m from the floor level.	29.83	Sq.m			
24	PL0072	Providing & laying cement plaster, finished with floating coat of neat cement 20mm plaster in C.M 1:3 for plinth band external	11.58	Sq.m			
25	PT0042	Providing and applying finishing coats Acrylic washable distemper, two coats on new work, including cement primer coat. Internal wall painting.	18.13	Sq.m			
26	PT0052	Providing and applying finishing coats Vinyl plastic emulsion paint, for cement, masonry, plaster, two coats on new work.	36.69	Sq.m			
27	PT0072	Providing and applying wood preservatives Coal tar, two coats on new work	1.00	L/s			

Name: - Construction of 4 unit toilet-2 at Tsiringtoed Central School. (Near Dzong)

Subject : - Bill of Quantity

Sl No	BSR Code	Description of item	Qty	Unit	Rate in		Amount
					figure	Words	
28	PT0112	Providing, preparing and applying Sumdang washable painting Thamar.	1.00	L/s			
29	PT0048	Providing and applying finishing coats High gloss synthetic enamel\for steel & wood work, two coats on new work.	26.80	Sq.m			
30	AR	P/F door type D-1 as per the drawing including MS hinges of 100mm, MS tower bolt of 100mm, MS sliding door bolt of 200mm & MS handle of 100mm excluding the painting works.	3.00	No.			
31	AR	P/F Window type W-1 as per the drawing including MS hinges of 75mm, MS tower bolt of 100mm, MS hook-and-eye of 100mm & MS handle of 75mm excluding the painting works.	3.00	No.			
32	WW0630	Providing & fixing anodised aluminium kicking plate, 4mm thick with necessary aluminium screws etc. complete	4.59	Sq.m			
33	PI0001	Providing & fixing CPVC pipes including CPVC fittings & clamps & repair walls 15mm	20.00	m			
34	PO0640	Providing & fixing H.D.P.E pipes including clamps & repair walls etc. complete 20mm	35.00	m			
35	PI0041	Providing & fixing Indian-type vitreous china w.c squatting pan, including 100 mm H.C.I P or S trap, 10 lit low level vitreous china cistern & fittings, repair walls 580mm, white Orissa-model	3.00	Each			
36	PI0260	Providing & fixing toilet paper holder C.P. brass	3.00	Each			
37	PI0275	Providing & fixing soap dish including brackets, wooden cleats, c.p. brass screws	3.00	Each			
38	PI0205	Providing & fixing c.p. bibcock 15mm, standard vertical, c.p knob	3.00	Each			
39	PI0177	Providing & fixing C.P. Brass shower fittings Shower arm, standard 15mm.	3.00	Each			

Name: - Construction of 4 unit toilet-2 at Tsiringtoed Central School.(Near Dzong)

Subject : - Bill of Quantity

Sl No	BSR Code	Description of item	Qty	Unit	Rate in		Amount
					figure	Words	
40	PI0185	Providing & fixing c.p. brass stop cock 15mm, standard, c.p knob.	6.00	Each			
41	PO0565	Providing & fixing P.V.C Nahani Trap 110mm inlet & 75mm outlet	3.00	Each			
42		Providing & fixing P.V.C door bend					
	PO0415	75mm dia	3.00	Each			
	PO0417	110mm dia	3.00	Each			
43		Providing & fixing P.V.C plain bend					
	PO0405	75mm dia	3	Each			
	PO0417	110mm dia	5	Each			
44		Providing & fixing P.V.C soil waste and vent pipes, single or double socketed, including pipe clip complete (excluding the cost of PVC fittings)					
	PO0370	75mm dia	6.20	m			
	PO0372	110mm dia	10.00	m			
45	PI0087	Providing & fixing white vitreous china wash basin, including C.I brackets, 15mm C.P. brass pillar taps, c.p. chain & rubber plug, 32mm pvc waste, 32mm dia. trap & union, repair walls Flat back wash basin 550x400mm with a pair of 15mm c.p. brass pillar taps.	3.00	Each			
46	PI0115	Providing & fixing pedestals for basins, white vitreous china, recessed back for pipes and necessary fittings.	3.00	Each			
47	PI0253	Providing & fixing c.p. towel rail 600 x 20mm with c.p brass brackets fixed to wooden cleats	3.00	Each			
48	PI0250	Providing & fixing 600x450mm bevelled edge mirror (superior glass) incl.4mm A.C sheet base fixed to wooden cleats	3.00	Each			
49	PO0610	Constructing Septic Tanks, in R.R Masonry in cement mortar 1:6, including fittings, C.I cover with frame, 40mm thick concrete flooring (40mm aggregates) cement plaster concrete base in C.C 1:4:8 etc. complete as per standard design 25 users	1.00	Each			

Name: - Construction of 4 unit toilet-2 at Tsiringtoed Central School.(Near Dzong)

Subject : - Bill of Quantity

Sl No	BSR Code	Description of item	Qty	Unit	Rate in		Amount
					figure	Words	
50	PO0600	Size 1200x1200x1200mm, filled with brick bats including 100mm SW drain pipe X 1200mm long	1.00	Each			
Total Amount for toilet-2 civil work (B)Nu.							

Total Amount in words: -

.....

.....only.

Name: - Construction of 4 unit toilet at Tsringtoed Central School.

Subject : - Bill of Quantity.(Drainage – C)

Sl No	BSR Code	Description of item	Qty	Unit	Rate in		Amount
					figure	Words	
1	EW0030	Earth work in excavation over areas, depth >300mm, width >1.5m, area >10 Sq.m on plan, including disposal of excavated earth within 50m lead and 1.5m lift & disposed soil to be neatly dressed Ordinary Soil	59.20	Cu.m			
2	EW0195	Filling of trenches, sides of foundations etc. in layers <200mm using selected excavated earth, ramming etc. within lead 50 m & lift 1.5m	41.4	Cu.m			
3	SM0072	Providing and laying Hand packed stone filling or soling with stones	10.6	Cu.m			
4	CW0005	Providing and laying in position plain cement concrete excluding the cost of centering and shuttering - All work upto plinth level.1:3:6 (1 cement : 3 sand : 6 graded crushed rock 20 mm nominal size)	7.03	Cu.m			
5	SM0006	Providing & laying Random Rubble Masonry with hard stone in foundation & plinth in cement mortar 1:5	17.8	Cu.m			
6	PL0041	Providing & laying 20mm cement plaster C.M 1:4.	59.2	Sq.m			
7	RC0083	Providing & fixing Thermo-Mechanically Treated reinforcement bar (Yield Strength 500 MPa) for R.C.C work including cutting, bending, binding and placing in position complete as per the drawing. 12mm diameter in wall & 10mm for inspection chamber cover.	6.96	Kg.			
			Total for Drainage (C) Nu.				

Name: - Construction of 4 unit toilet-2 at Tseringtoed Central School.(Near Dzong)

Subject : - Bill of Quantity(Electrical Work -D)

Sl No	BSR Code	Description of item	Qty	Unit	Rate in		Amount
					figure	Words	
1		Supplying and fixing of PVC & HDPE pipe on recessed including all accessories such as screws, bends, elbows, Tees, corners, etc. complete as required					
	CD0221	25mm HDPE	70.00	mtr			
2		Provide & Draw Single Core 1.1KV grade PVC insulated copper conductor cable in existing HDPE concealed pipe					
	WC0104	2x1.5 sq.mm	20.00	mtr			
	WC0116	2x2.5 sq.mm	50.00	mtr			
3		Supplying & fixing of modular metal boxes for switch/socket outlet/switch socket combined/ gang switches with fibre sheet cover including painting etc as required (Category A)					
	BX0053	Modular metal box 4way	1.00	each			
4		Supplying & fixing of 6A switch on existing metal box (recessed or surface) including necessary cutting, connection testing etc. as required.PVC/metal / moulded tough					
	SS0060	10A switch SP 1-way	4.00	each			
	MR	Square Box	4.00	each			
	SS0232	Angle holder (heavy duty, brass plunger)	4.00	each			
	MR	LED 9 W	4.00	each			
		CONTROL GEAR & BUS BAR					
5		Supply of miniature circuit breaker (MCB) single pole, 230 volt A.C complete with all accessories suitable to fix on a din-bar etc. as required Legrand/GE/L&T/ Merlin makes					
	GB0270	SP MCB 6A	1.00	each			
6		Supply of miniature circuit breaker (MCB) DP, 230 volt A.C complete with all accessories suitable to fix on a din-bar etc. as required Legrand/GE/L&T/ Merlin makes					
	GB0313	DP 20A	1.00	each			

Name: - Construction of 4 unit toilet-2 at Tsiringtoed Central School.(Near Dzong)

Subject : - Bill of Quantity

Sl No	BSR Code	Description of item	Qty	Unit	Rate in		Amount	
					figure	Words		
7		Supply of SPN distribution board (DIN type) without door, 230 volt A.C complete with all accessories without MCB/isolator/RCCB out going or incoming etc. as required						
	GB0515	4 way	1.00	each				
		Erection/installation						
8		Installation, testing and commissioning of prewired fluorescent fittings of all recessed type complete with all accessories and tubes including on ceiling including connection with PVC insulated copper conductor						
	EI0081	1.5 sq.mm single core cable 1.1 KV grade	4.00	each				
9		Installation, testing and commissioning of SPN DB (DIN type) with no door or archylic door complete with all accessories to accommodate incoming RCCB DP 63A sensitivity 30/100/300mA and outgoing SP MCB 6/10/16A prefabricated MS surface / MS cubical control panel b						
	EI0495	4 way	1.00	each				
		Total for One Block (Electrical work-D) Nu.						

Total Amount for 1 Block (D)	Nu.
Total Amount for 2 Blocks (2*D=E)	Nu.

SI #	Name of Work	Quoted Amount
1.	<i>Total Amount for toilet -1 (A) Nu.</i>
2.	<i>Total Amount for toilet -2 (B) Nu.</i>
3.	<i>Total Amount for Drainage(C) Nu.</i>
4.	<i>Total Amount for Electrical Work (E)Nu.</i>
5.	<i>Grand Quoted Amount (A+B+C+E) Nu.</i>

Amount in words: -

.....

.....

.....

.....

.....

.....

.....*Only.*

Sign & Seal.

Name of the firm.....

Name Proprietor :-

CDB No: -

Contract No. :-

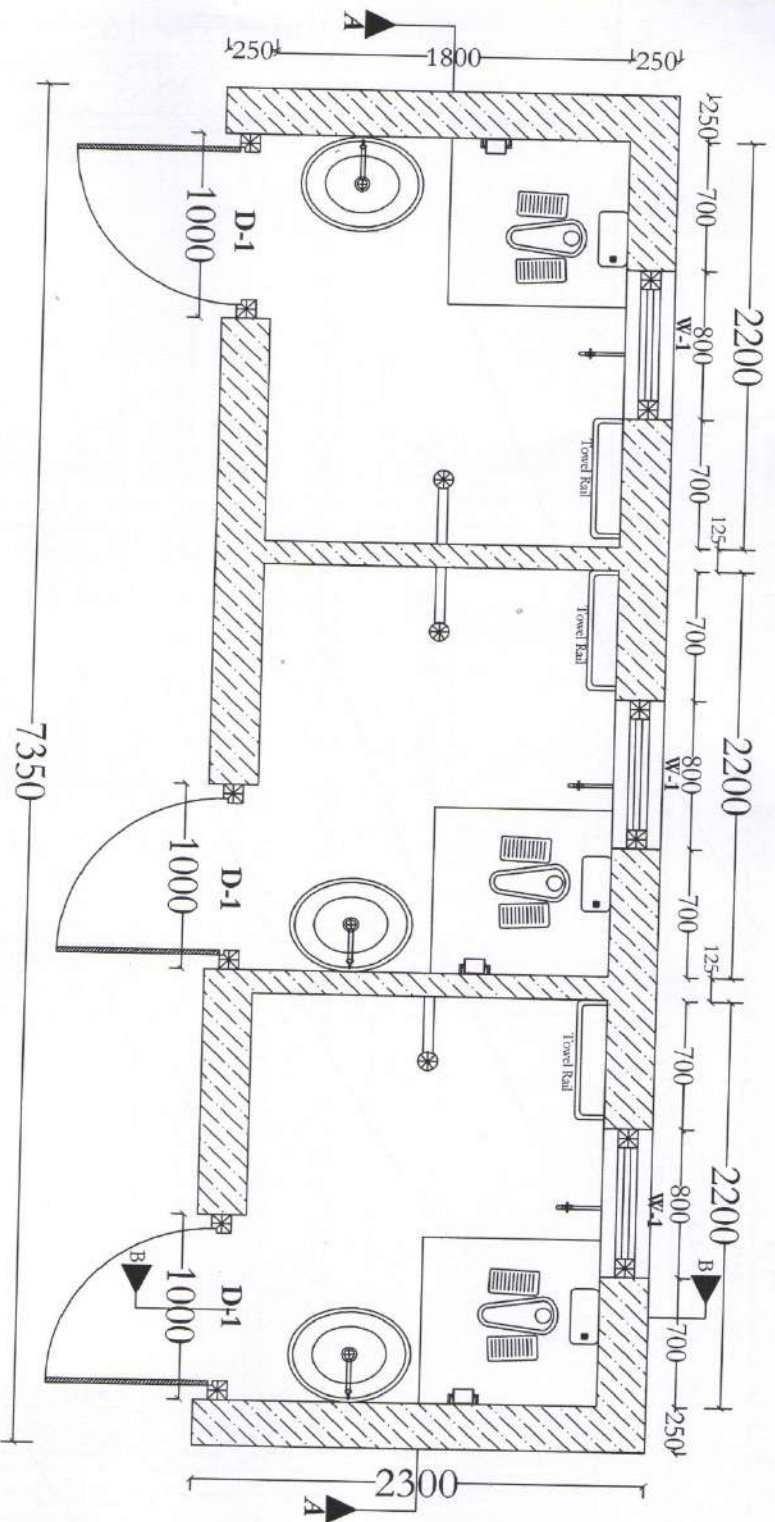

DZONGKHAG ENGINEERING SECTOR
TSIRANG DZONGKHAG

Work:- Const. of 3 unit toilet-1 at Tiringroed Central School.
Title:- Plan of the toilet.

Designed & Drawn by:-

 Prem Bdr. Challey AR/DES

Checked by:-



 Dzongkhag Engineer.

Drawing No :- 01

Date :- 19.12.2018

Scale :- NTS

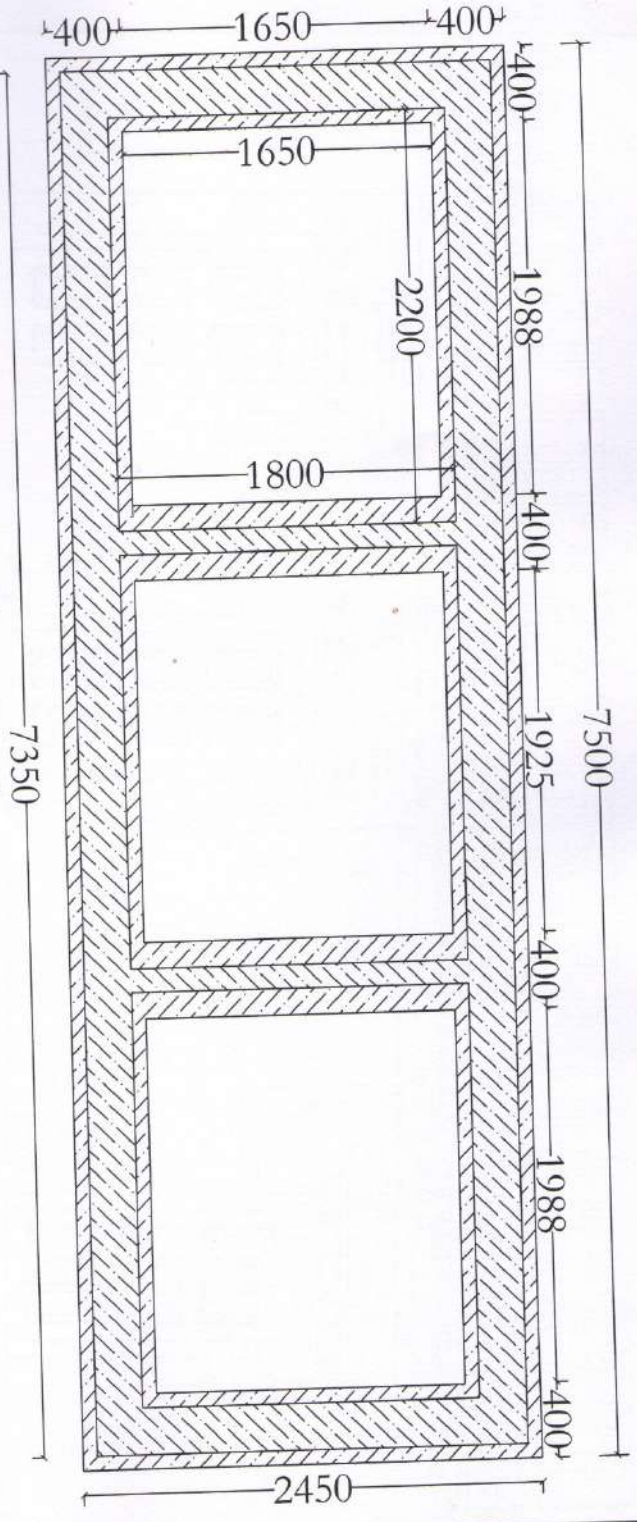
Revision:



Plan at Floor Level.

 <p>DZONGKHAG ENGINEERING SECTOR TSIRANG DZONGKHAG</p>		<p>Work: Const. of 3 Unit toilet-1 at Tsiangtse Central School.</p>		<p>Drawing No :- 02</p>	
<p>Title:- Plan at floor level.</p>		<p>Designed & Drawn by:- <i>Prem Bdr Challey</i> Prem Bdr Challey AE/DES</p>		<p>Checked by:- <i>[Signature]</i> Dzongkhag Engineer.</p>	
		<p>Date :- 19.12.2019</p>		<p>Scale :- NTS</p>	
		<p>Revisions:</p>			

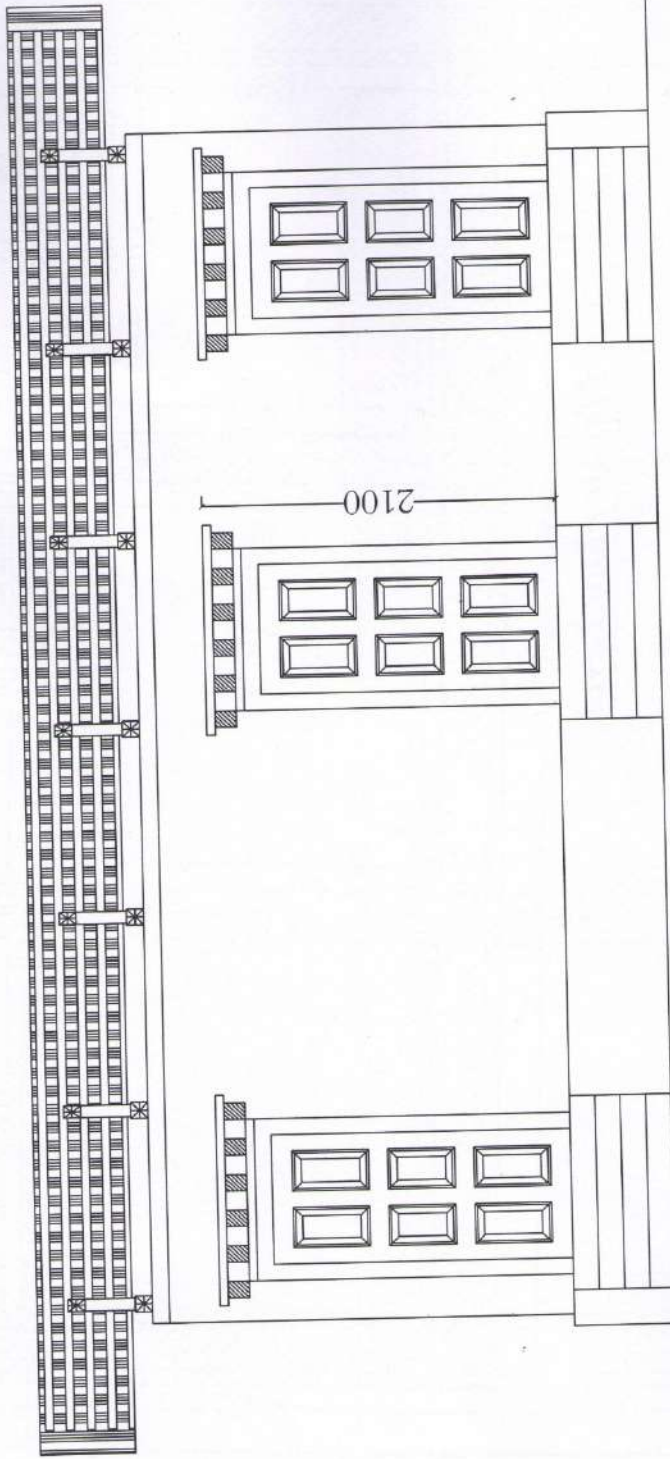

Front Elevation

 <p>DZONGKHAG ENGINEERING SECTOR TSIRANG DZONGKHAG</p>	<p>Work:- Const. of 3 Unit toilet-1 at Tsirangtoe Central School. Title:- Front Elevation.</p> <p>Designed & Drawn by:- <i>[Signature]</i> Prem Babu Challey AE/D&ES</p> <p>Checked by:- <i>[Signature]</i> Dzongkhag Engineer.</p>	<p>Drawing No :- 03</p> <p>Date :- 19.12.2019</p> <p>Scale :- NTS</p> <p>Revision:</p>
-------------------------------------------------------------------------------------------------------------------------------------------------	-----------------------------------------------------------------------------------------------------------------------------------------------------------------------------------------------------------------------------------------------------------------	----------------------------------------------------------------------------------------

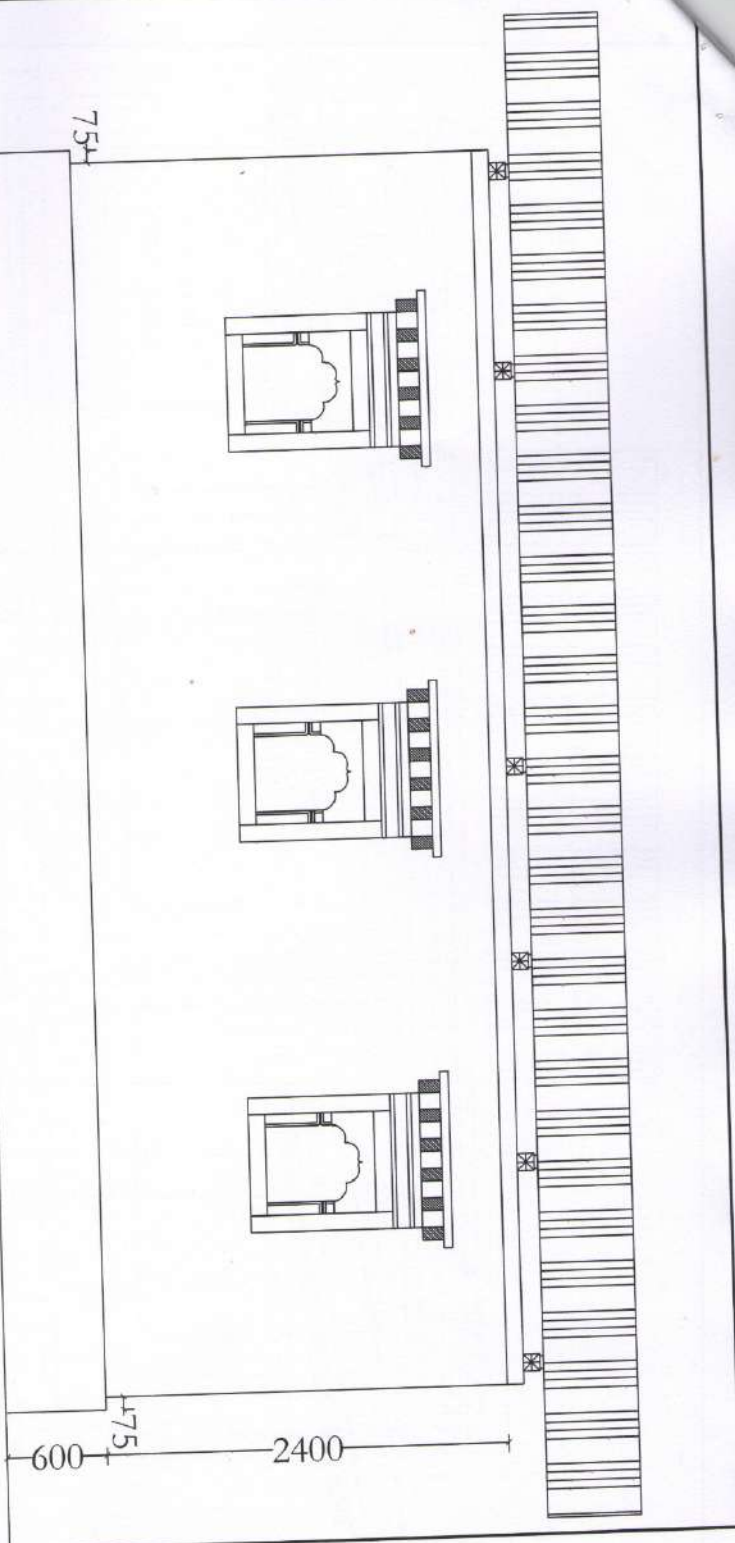

Back Elevation

Work-Const. of 3 Unit toilet-1 at Tirangro Central School.

Title:- Back Elevation.



DZONGKHAG ENGINEERING SECTOR
TSIRANG DZONGKHAG

Designed & Drawn by:- <i>Prern Bdr. Shately AE/DSS</i>	Checked by:- <i>Dzongkhag Engineer.</i>
-----------------------------------------------------------	--------------------------------------------

Drawing No :-04
Date :- 19.12.2019
Scale :- NTS
Revisions:

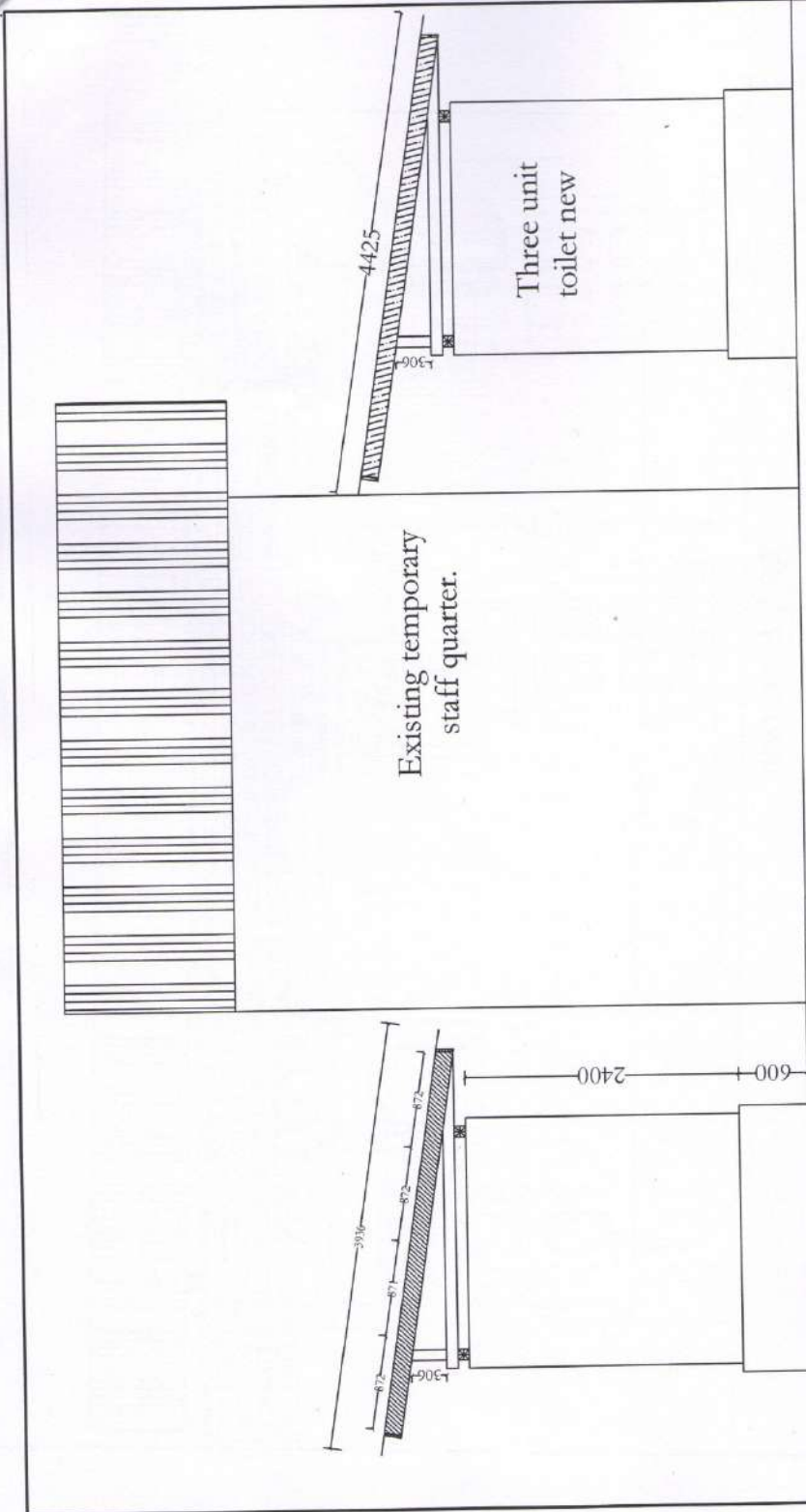

Side Elevation

 DZONGKHAG ENGINEERING SECTOR TSIRANG DZONGKHAG	Work:- Const. of 3 Unit toilet-1 at Tsirangtoe Central School.		Drawing No :- 05
	Title:- Side Elevation.		Date :- 19.12.2019
Designed & Drawn by:- 		Scale :- NTS	
Prem. Bdr. Challey AE/DES		Checked by:- 	
		Revision:	
		Dzungkhag Engineer.	

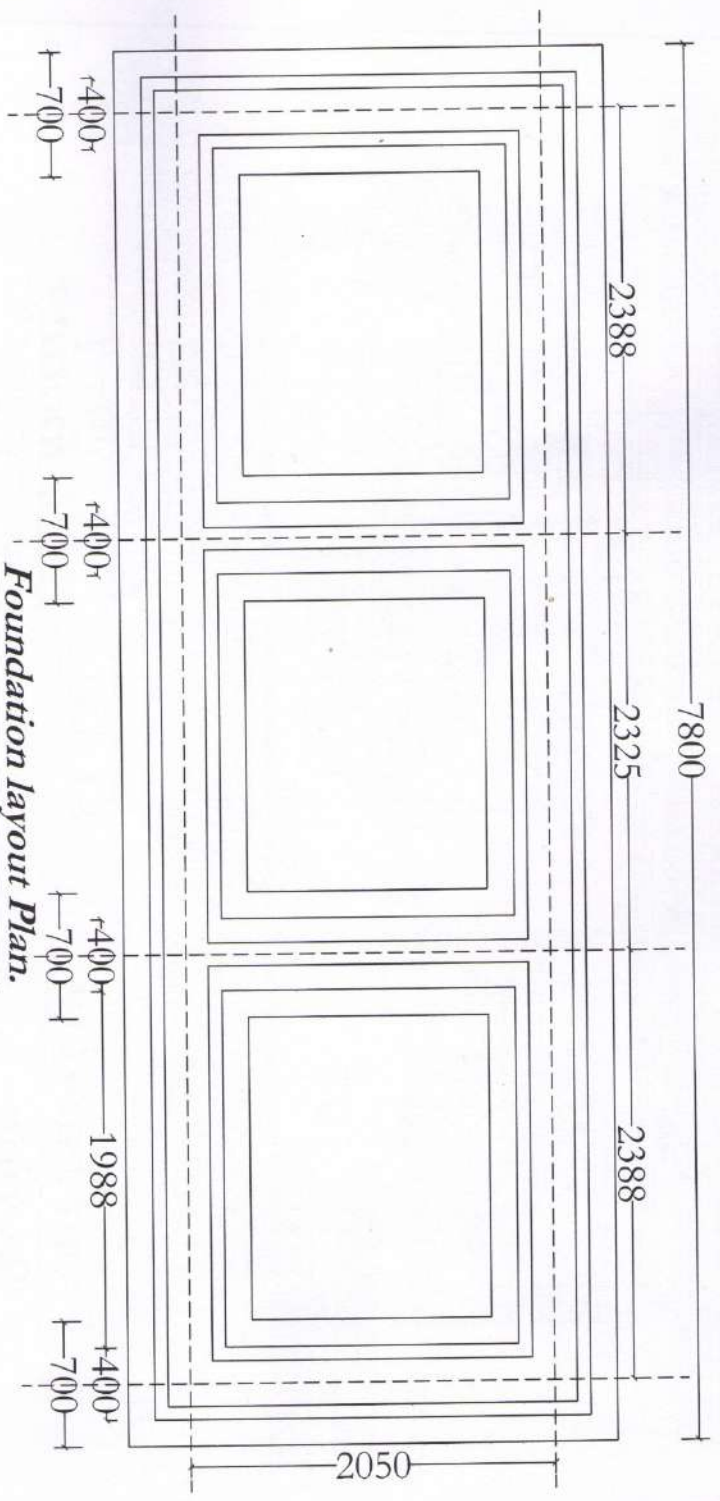

DZONGKHAG ENGINEERING SECTOR
 TSIRANG DZONGKHAG



Work:- Const. of 3 Unit toilet-1 at Tsirangroe Central School.
 Title:- Side Elevation.

Designed & Drawn by:-
 Prem. Bar. Chhaley AE/D&S

Checked by:-
 Dzongkhag Engineers.

Drawing No :- 06
 Date :- 19.12.2019
 Scale :- NTS
 Revisions:

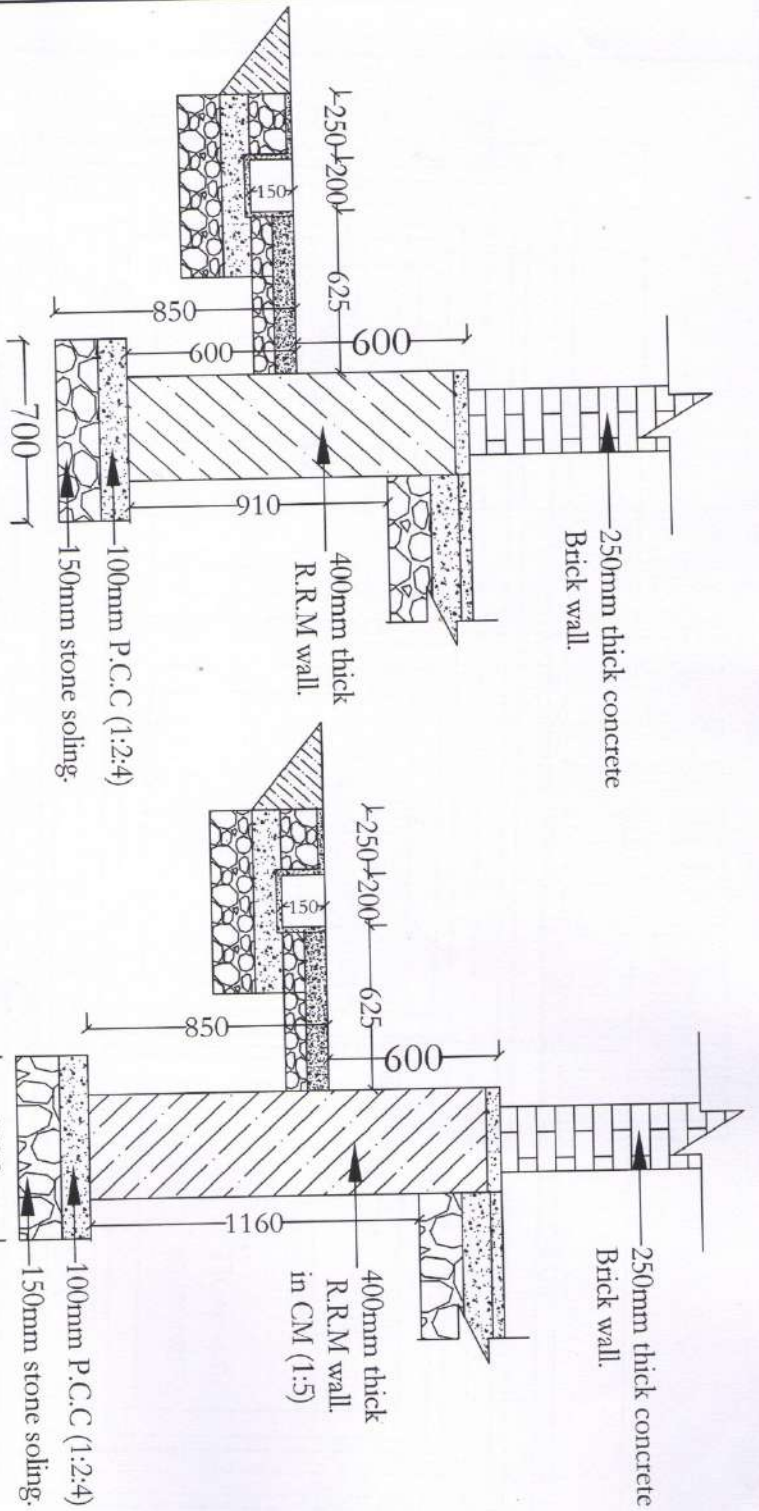

Front Footing Section

Back footing Section

Work:- Const. of 3 Unit toilet-1 at Tisrangtoe Central School.

Drawing No :- 07

Title:- Footing Section.

Date :- 19.12.2019

Designed & Drawn by:-

Checked by:-

Prem Bdr. Challey AE/DSS

Dzongkhag Engineer.

Revisions:

Scale :- NTS



DZONGKHAG ENGINEERING SECTOR
TISRANG DZONGKHAG

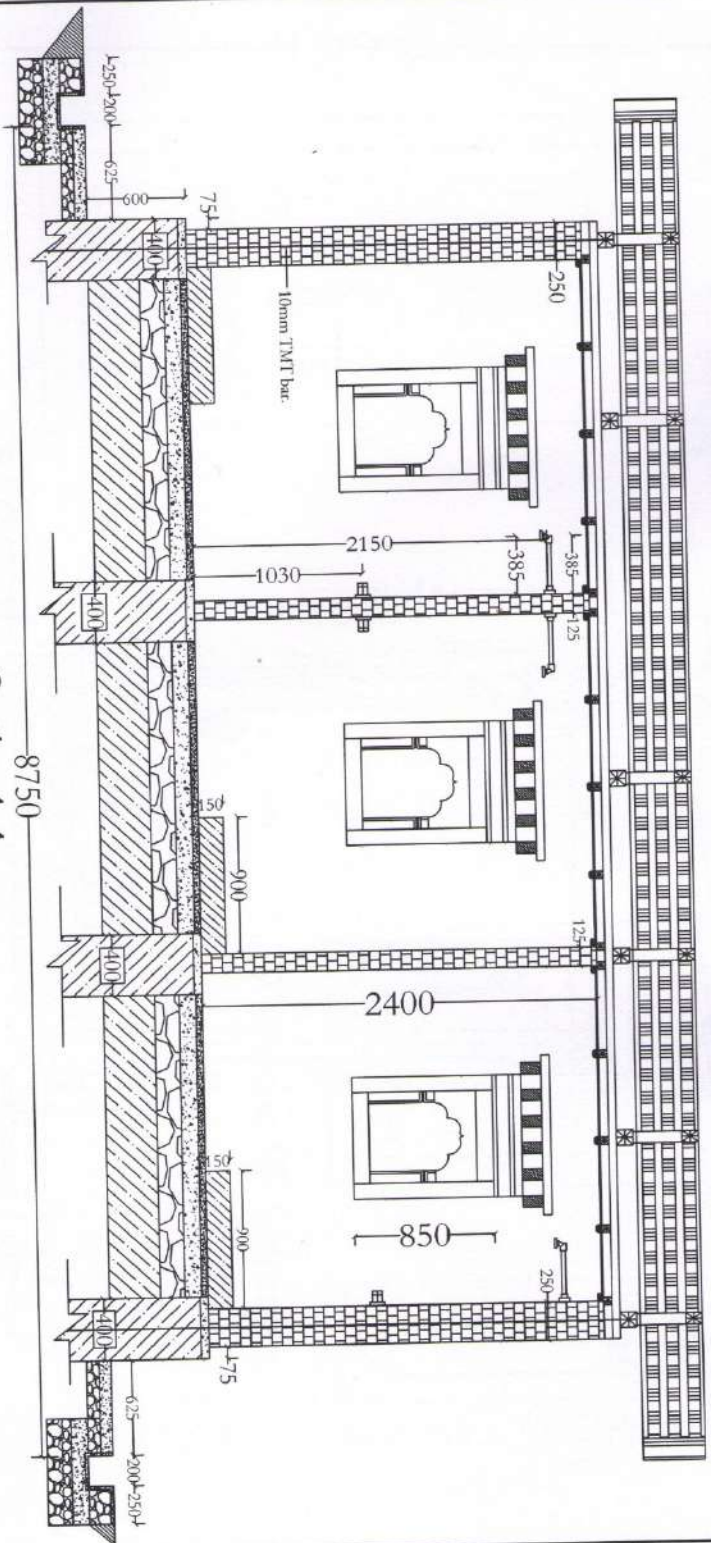

Section A-A.

<p>Work:- Const. of 3 Unit toilet-1 at Tisrangtoe Central School.</p>		<p>Drawing No :- 08</p>	
<p>Title:- Section A-A.</p>		<p>Date :- 19.12.2019</p>	
<p>Designed & Drawn by:- <i>[Signature]</i></p>		<p>Checked by:- <i>[Signature]</i> Dzongkhag Engineer.</p>	
<p>Prep. Bdr. Chalegy AE/DAS</p>		<p>Revisions:</p>	
<p>DZONGKHAG ENGINEERING SECTOR TSIRANG DZONGKHAG</p>			



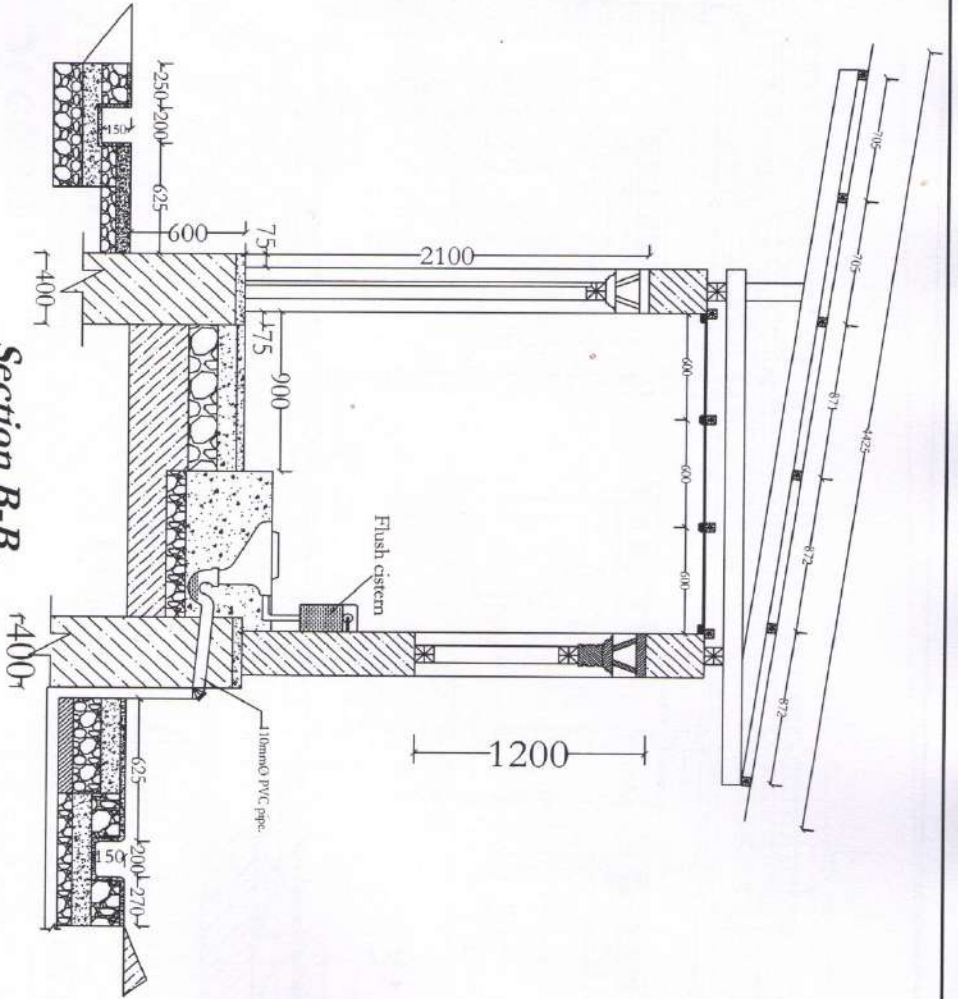

Section B-B.

Work:- Const. of 3 Unit toilet-1 at T'srangtoe Central School.

Title:- Section B-B.

Designed & Drawn by:-

Prem Bdr. Challey AE/DES

Checked by:-

Dzongkhag Engineer.

Drawing No :- 09

Date :- 19.12.2019

Scale :- NTS

Revisions:



DZONGKHAG ENGINEERING SECTOR
TSIRANG DZONGKHAG

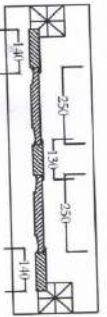
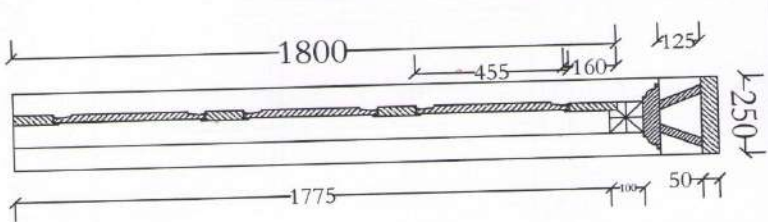
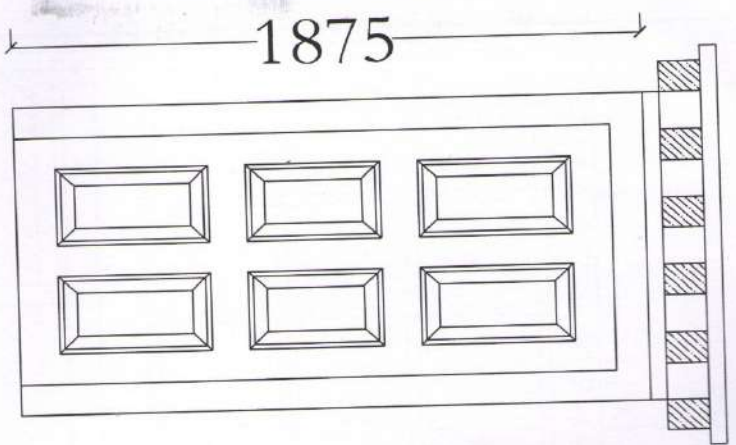

↑250↓

Door D-1 details.

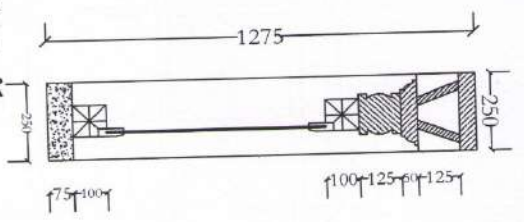
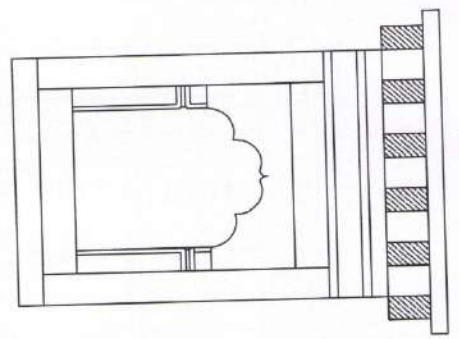

Window W-1 details.

Work:- Const. of 3 Unit toilet-1 at Tsirangtoe Central School.

Title:- Opening details.

Drawing No :- 10

Date :- 19.12.2019

Scale :- NTS

Revisions:



DZONGKHAG ENGINEERING SECTOR
TSIRANG DZONGKHAG

Designed & Drawn by:-
Shelley
Prern Bdr. Chakky AE/DSS

Checked by:-
[Signature]
Dzongkhag Engineer.

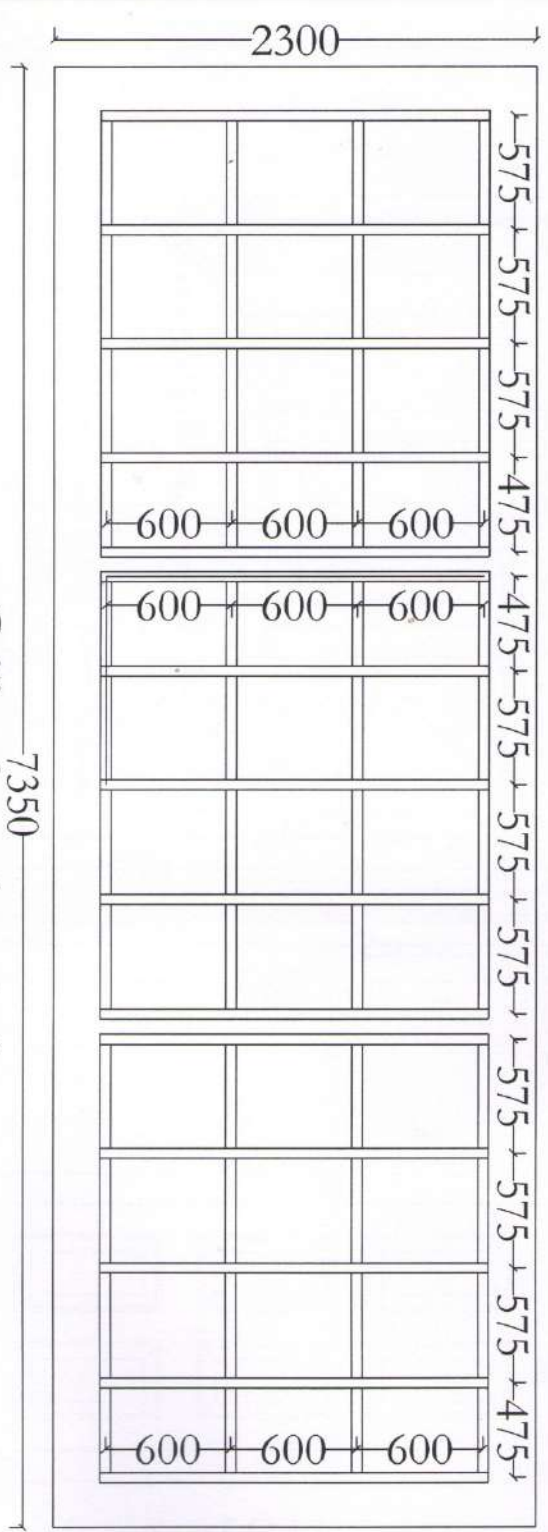

Ceiling frame layout plan.

 DZONGKHAG ENGINEERING SECTOR TSIRANG DZONGKHAG	Work-Const. of 3 Unit toilet-1 at Tsirangtoe Central School.		Drawing No :-11
	Title:-Ceiling frame layout plan.		
Designed & Drawn by:-  Prem Bar. Chetley AE/DSS		Checked by:-  Dzungkhag Engineer.	Scale :- NTS
Revisions:			_____
_____			_____

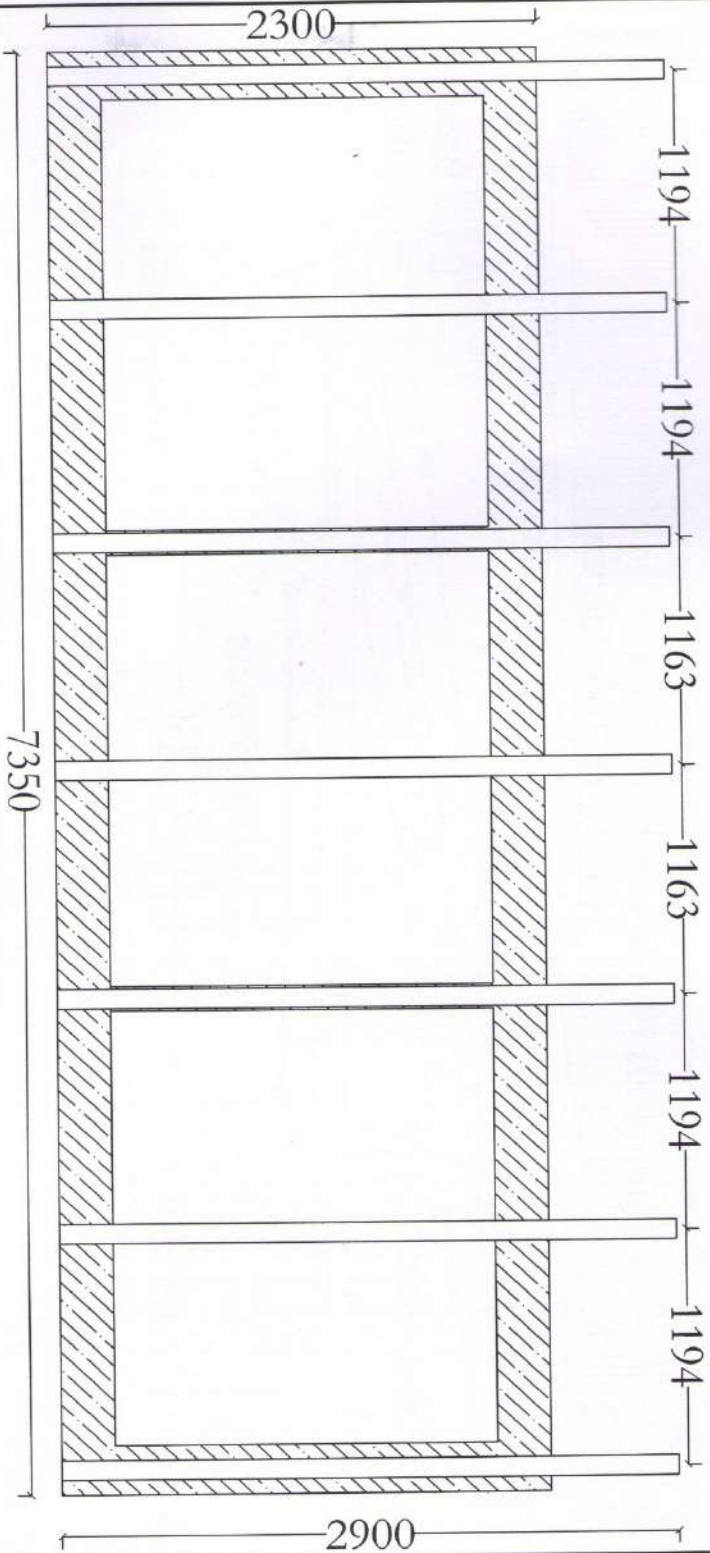

Truss layout plan.

 <p>DZONGKHAG ENGINEERING SECTOR TSIRANG DZONGKHAG</p>		<p>Work:- Const. of 3 Unit toilet-1 at Tsirangtoe Central School.</p>		<p>Drawing No :- 12</p>	
<p>Title:- Truss layout plan.</p>		<p>Designed & Drawn by:- <i>Prern Bdr. Chetley AE/DHS</i></p>		<p>Checked by:- <i>Dzongkhag Engineer.</i></p>	
		<p>Date :- 19.12.2019</p>			
		<p>Scale :- NTS</p>			
		<p>Revisions:</p>			

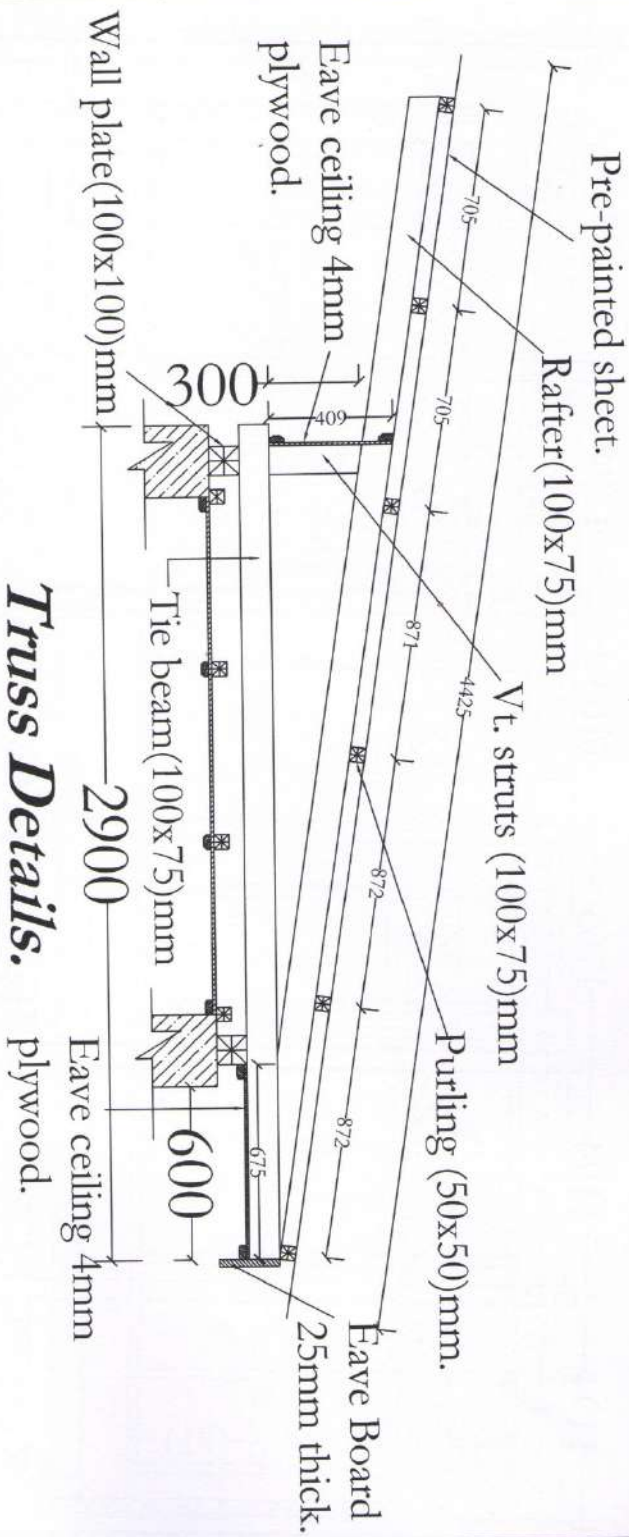

Work:- Const. of 3 Unit toilet-1 at Tirangroo Central School.

Title:- Truss layout plan.

Drawing No :- 13

Date :- 19.12.2019

Scale :- NTS

Revisions:



DZONGKHAG ENGINEERING SECTOR
TSIRANG DZONGKHAG

Designed & Drawn by:-

Prem Bdr. Challey AE/DPS

Checked by:-

Dzongkhag Engineer.

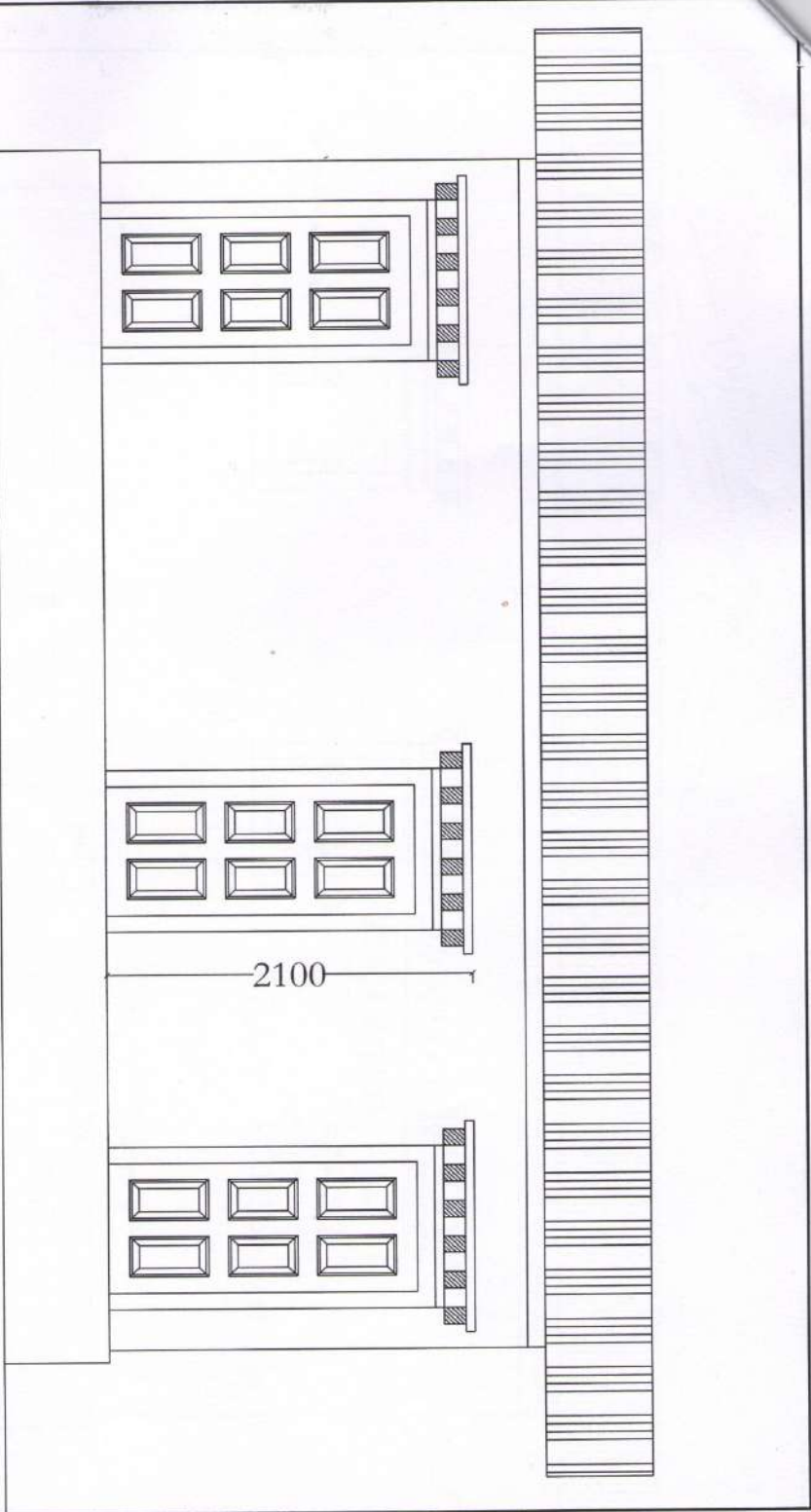

Front Elevation *Note:- Plan for both the toilet is same except Elevation.*

 <p>DZONGKHAG ENGINEERING SECTOR TSIRANG DZONGKHAG</p>		<p>Work:- Const. of 3 Unit toilet-2 at Tsiangro Central School.</p>		<p>Drawing No :- 14</p>	
<p>Title:- Front Elevation for toilet-2.</p>		<p>Designed & Drawn by:- <i>Prem Bdr. Phaley</i></p>		<p>Checked by:- <i>[Signature]</i></p>	
<p>Prem Bdr. Phaley AE/DES</p>		<p>Dzongkhag Engineer.</p>		<p>Date :- 19.12.2019</p>	
				<p>Scale :- NTS</p>	
				<p>Revisions:</p>	

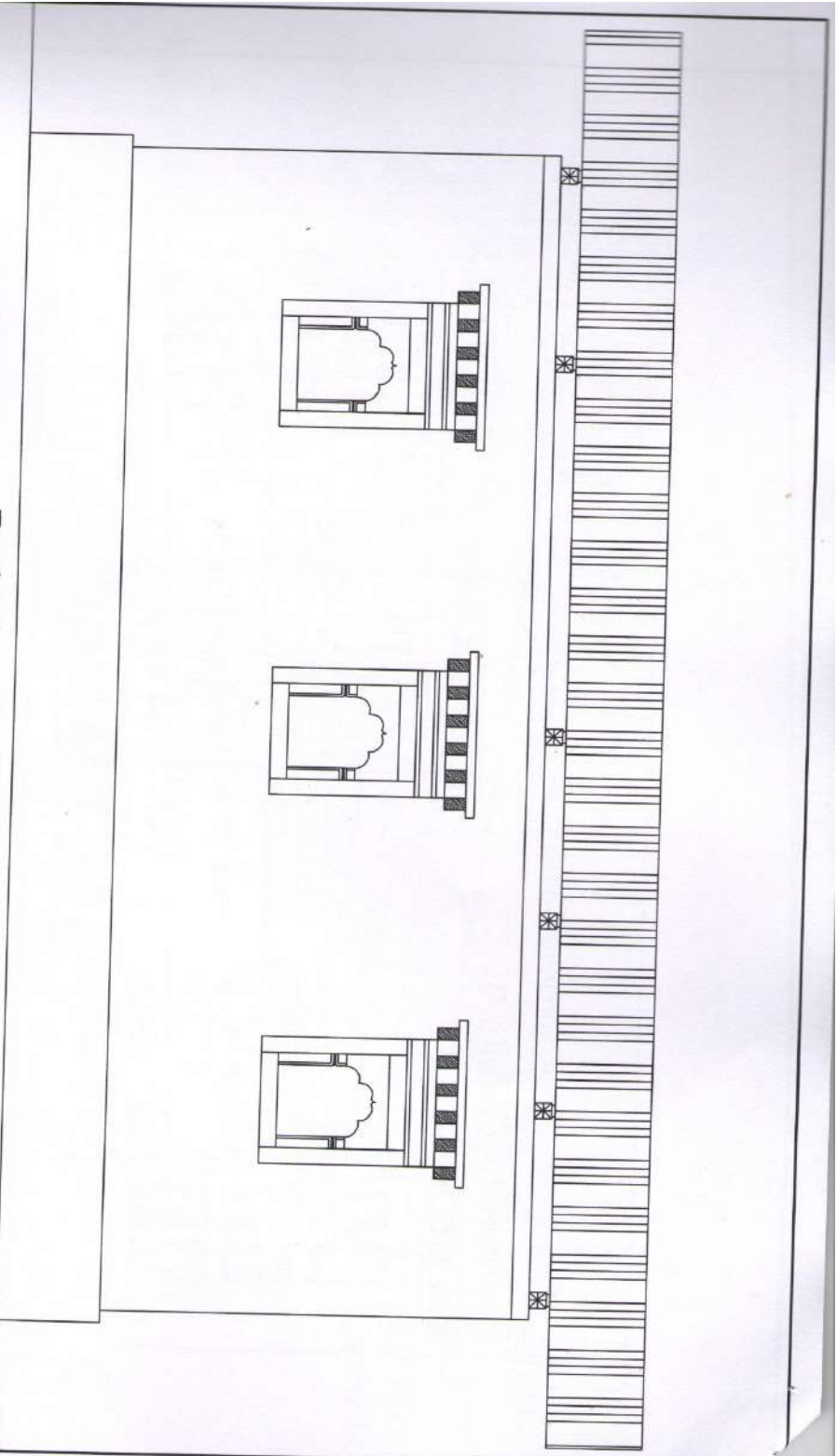

Back Elevation *Note:- Plan for both the toilet is same except Elevation.*

Work:- Const. of 3 Unit toilet-2 at Tirangro Central School.

Title:- Back Elvation of toilet-2.

Designed & Drawn by:-

Shubham
Prem Bdr. Chakley AR/DES

Checked by:-

[Signature]
Dzongkhag Engineer.

Drawing No :- 15

Date :- 19.12.2019

Scale :- NTS

Revisions:

DZONGKHAG ENGINEERING SECTOR
TIRANG DZONGKHAG



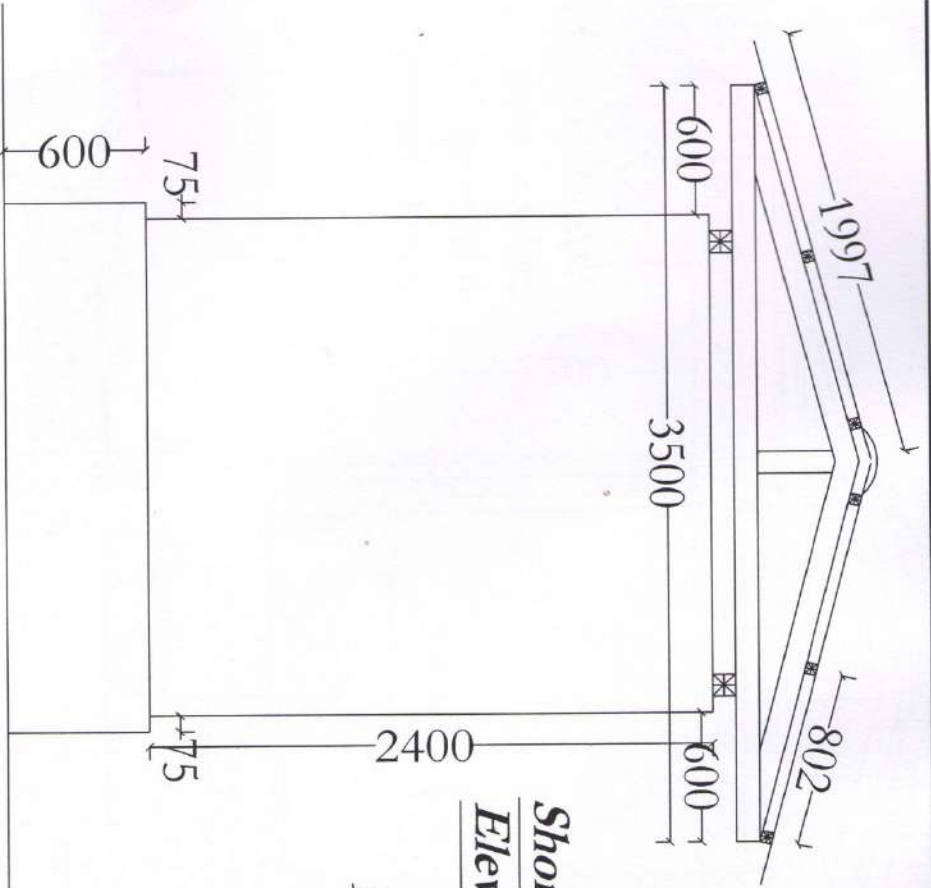

Shorter side
Elevation

Note:- Plan for both the toilet is same except Elevation.



DZONGKHAG ENGINEERING SECTOR
TSIRANG DZONGKHAG

Work:- Const. of 3 Unit toilet-2 at Tsirangroe Central School.

Title:- S/s Elevation of toilet-2.

Designed & Drawn by:-

Prem Bdr. Challey AB/DSS

Checked by:-

Dzongkhag Engineer.

Drawing No :- 16

Date :- 19.12.2019

Scale :- NTS

Revisions:

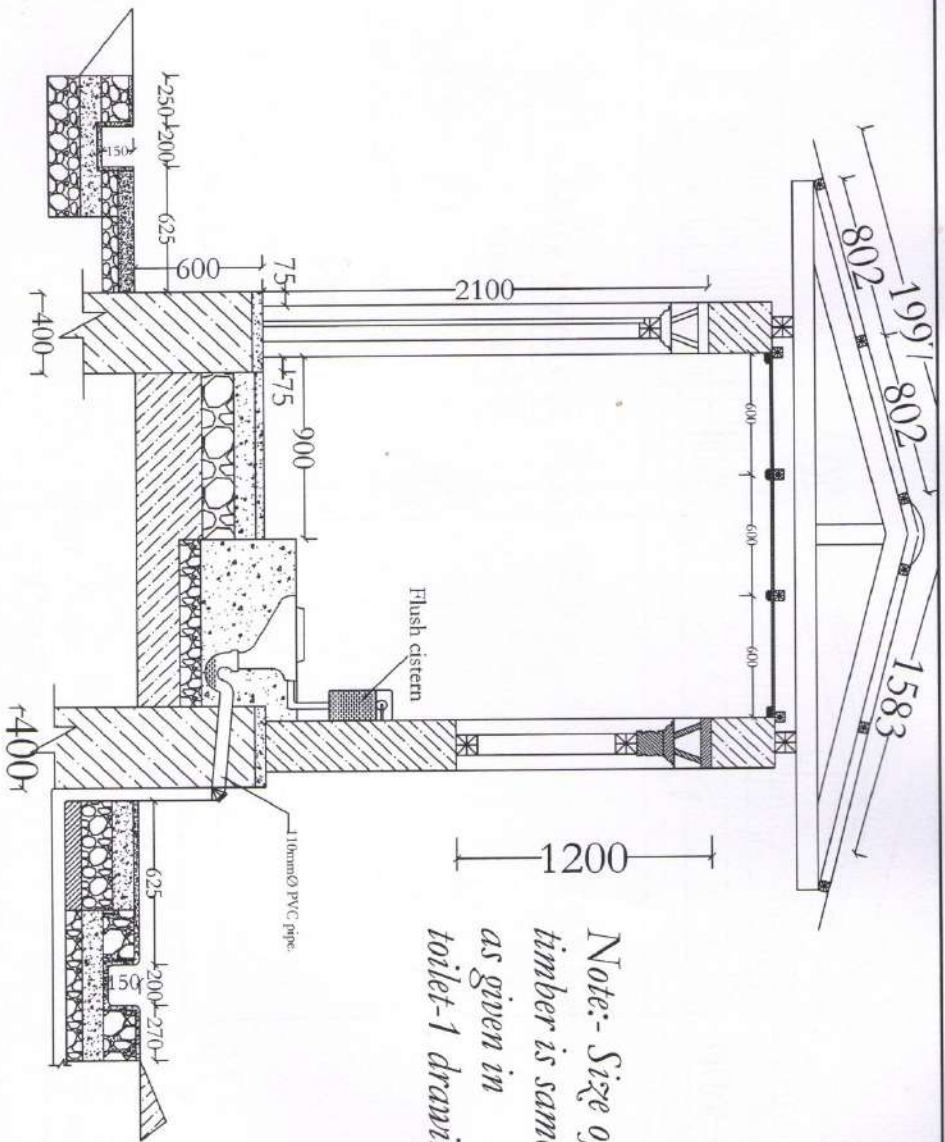

Note:- Size of the timber is same as given in toilet-1 drawing.

Work: Const. of 3 Unit toilet-2 at Tirangtoe Central School.

Title: Cross Section in shorter direction of toilet-2.

Drawing No :- 17

Date :- 19.12.2019

Scale :- NTS

Revisions:

DZONGKHAG ENGINEERING SECTOR
TSIRANG DZONGKHAG



Designed & Drawn by:-

Shally

Checked by:-

[Signature]

Prern Bdr. Ekallye AB/DSS

Dzongkhag Engineer.

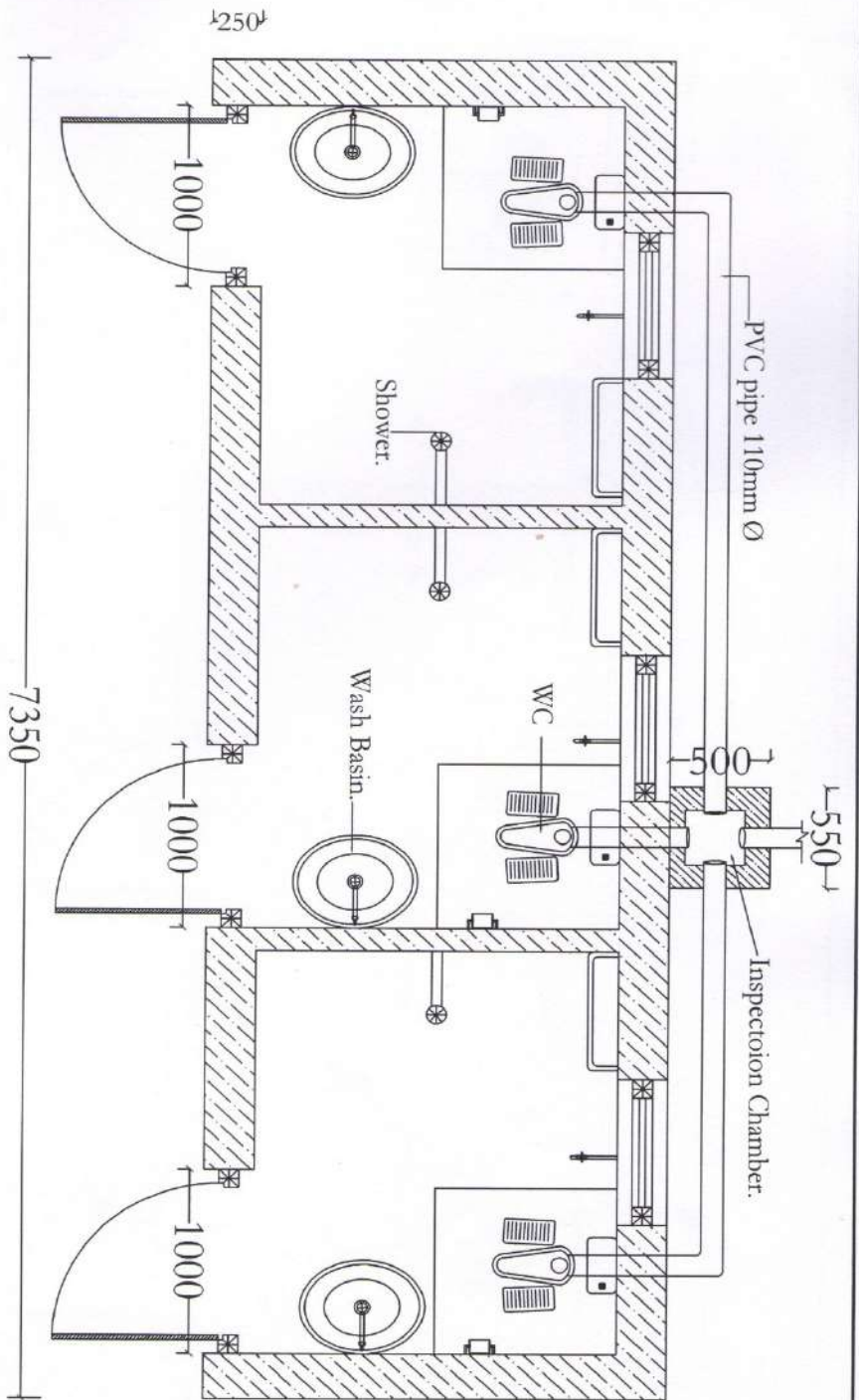

Work:- Const. of 3 Unit toilet-2 at Tirangtoe Central School.

Title:- Plumbing details for both toilet.

Designed & Drawn by:-

Prem Bdr. Chakley AE/DSS

Checked by:-

Dzongkhag Engineer.

Drawing No :- 18

Date :- 19.12.2019

Scale :- NTS

Revisions:

DZONGKHAG ENGINEERING SECTOR
TSIRANG DZONGKHAG

